

# Collection Book *n.* 3

# Contents

1. Abacus (A—Z)	007
2. Collection Part I	017
3. Corporate Identity	177
4. Collection Part II	201
5. Technical Sheet	379

# Products

020	Blyn	238	Olimpia	364	Fizzy
026	Gast	242	Morgans	368	Dindi
042	Arita	246	Iki	378	Canouan
052	Ocean	250	Riviera	376	Viae
062	Blom	254	Cocoon		
070	Siloe	258	Bak		
080	Paipu	266	Square		
088	Twin	278	Bridge		
092	Loren	284	Hudson		
098	Clubby	290	Public		
106	Bler	296	Nisida		
110	Wilton	300	Hollow		
118	Myon	304	Latina		
130	Syren	310	Heta		
136	Quattro	314	Comb		
142	Otto	320	Doni		
148	Bella	326	Maio		
158	Winnie	328	Sahrai		
168	Twain	332	Lyo		
172	Doa	336	Mea		
204	Caruso	342	Sofy		
210	Elf	346	Lilly		
216	Artù	350	Aria		
224	Privè	354	Dante		
232	Ponza	360	Ele		

# *Index:*



# 1.Abacus

(a-z)

## Chairs & Armchairs ↳



Aria  
FG 545.00  
Shooting p. 350 — 353  
Details p. 380



Bella  
FG 320.01  
Shooting p. 148—157  
Details p. 380



Bella P  
FG 320.03  
Shooting p. 148—157  
Details p. 380



Bella H  
FG 320.00  
Shooting p. 148—157  
Details p. 380



Bella HP  
FG 320.02  
Shooting p. 148—157  
Details p. 380



Bella H GM  
FG 320.06  
Shooting p. 148—157  
Details p. 380



Bella HP GM  
FG 320.08  
Shooting p. 148—157  
Details p. 380



Bella HP W  
FG 320.12  
Shooting p. 148—157  
Details p. 380



Bella HW  
FG 320.10  
Shooting p. 148—157  
Details p. 380



Blyn  
FG 533.00  
Shooting p. 20—25  
Details p. 381



Blyn P  
FG 533.01  
Shooting p. 20—25  
Details p. 381



Dindi  
FG 448.00  
Shooting p. 368—371  
Details p. 382



Doa  
FG 464.03  
Shooting p. 172—175  
Details p. 382



Doa P  
FG 464.02  
Shooting p. 172—175  
Details p. 382



Ele  
FG 457.00  
Shooting p. 360—363  
Details p. 382

# Abacus



Elf  
FG 497.00  
Shooting p. 210—215  
Details p. 383



Elf P  
FG 497.01  
Shooting p. 210—215  
Details p. 383



Iki W  
FG 333.05  
Shooting p. 246—249  
Details p. 384



Iki PW  
FG 333.06  
Shooting p. 246—249  
Details p. 384



Olimpia P  
FG 501.01  
Shooting p. 238—241  
Details p. 387



Ponza  
FG 405.00  
Shooting p. 232—237  
Details p. 387



Public  
FG 506.00  
Shooting p. 290—295  
Details p. 388



Public P  
FG 506.01  
Shooting p. 290—295  
Details p. 388



Latina  
FG 260.00  
Shooting p. 304—309  
Details p. 384



Latina P  
FG 262.01  
Shooting p. 304—309  
Details p. 384



Latina H  
FG 261.00  
Shooting p. 304—309  
Details p. 384



Latina HP  
FG 262.00  
Shooting p. 304—309  
Details p. 384



Siloe  
FG 534.00  
Shooting p. 70—79  
Details p. 389



Siloe P  
FG 534.01  
Shooting p. 70—79  
Details p. 389



Siloe W  
FG 534.10  
Shooting p. 70—79  
Details p. 389



Siloe PW  
FG 534.11  
Shooting p. 70—79  
Details p. 389



Lilly  
FG 408.00  
Shooting p. 346—349  
Details p. 385



Lilly H  
FG 408.01  
Shooting p. 346—349  
Details p. 385



Lyo  
FG 352.00  
Shooting p. 332—335  
Details p. 385



Mea C  
FG 462.05  
Shooting p. 336—341  
Details p. 386



Sofy  
FG 446.00  
Shooting p. 342—345  
Details p. 390



Square  
FG 465.00/465.20  
Shooting p. 266—277  
Details p. 390

## Chairs with Casters ↳



Canouan D  
FG 282.03  
Shooting p. 372—375  
Details p. 381



Mea HC  
FG 461.05  
Shooting p. 336—341  
Details p. 386



Nisida  
FG 342.00  
Shooting p. 296—299  
Details p. 386



Nisida P  
FG 342.01  
Shooting p. 296—299  
Details p. 386



Olimpia  
FG 501.00  
Shooting p. 238—241  
Details p. 387



Canouan 5  
FG 282.05  
Shooting p. 372—375  
Details p. 381



Mea AR  
FG 462.00  
Shooting p. 336—341  
Details p. 386



Mea H AR  
FG 461.00  
Shooting p. 336—341  
Details p. 386

# Abacus

## Stools



Bella B  
FG 320.16  
Shooting p. 148—157  
Details p. 381



Bella C  
FG 320.15  
Shooting p. 148—157  
Details p. 381



Bella CP  
FG 320.14  
Shooting p. 148—157  
Details p. 381



Siloe B  
FG 534.13  
Shooting p. 70—79  
Details p. 389



Siloe C  
FG 534.12  
Shooting p. 70—79  
Details p. 389



Square B  
FG 465.03/465.23  
Shooting p. 266—277  
Details p. 390



Square C  
FG 465.02/465.22  
Shooting p. 266—277  
Details p. 390



Bella GP  
FG 320.04  
Shooting p. 148—157  
Details p. 381



Elf B  
FG 497.11  
Shooting p. 210—215  
Details p. 383



Elf C  
FG 497.10  
Shooting p. 210—215  
Details p. 383



Elf GP  
FG 497.12  
Shooting p. 210—215  
Details p. 383



Fizzy Metal Backrest  
FG 458.00  
Shooting p. 364—367  
Details p. 383



Fizzy Leather Backrest  
FG 458.01  
Shooting p. 364—367  
Details p. 383



Latina CP  
FG 265.04  
Shooting p. 304—309  
Details p. 384



Latina GP  
FG 265.00  
Shooting p. 304—309  
Details p. 384



Lilly B  
FG 408.03  
Shooting p. 346—349  
Details p. 385



Lilly C  
FG 408.02  
Shooting p. 346—349  
Details p. 385



Lilly GP  
FG 408.04  
Shooting p. 346—349  
Details p. 385



Ponza GP  
FG 405.07  
Shooting p. 232—237  
Details p. 387

## Lounge Chairs



Clubby  
FG 493.00/493.20/493.30  
Shooting p. 98—105  
Details p. 381



Cocoon  
FG 495.00  
Shooting p. 254—257  
Details p. 382



Heta  
FG 426.00  
Shooting p. 310—313  
Details p. 383



Hollow  
FG 482.00/482.01  
Shooting p. 300—303  
Details p. 384



Ocean  
FG 527.00/527.20  
Shooting p. 52—61  
Details p. 386



Public L  
FG 506.02  
Shooting p. 290—295  
Details p. 388



Riviera  
FG 499.00  
Shooting p. 250—253  
Details p. 388



Sahrai  
FG 471.00  
Shooting p. 328—331  
Details p. 389



Syren  
FG 542.00  
Shooting p. 130—135  
Details p. 389



Square L  
FG 465.01/465.21  
Shooting p. 266—277  
Details p. 390



Winnie  
FG 483.00  
Shooting p. 158—167  
Details p. 391

## Poufs



Clubby Pouf  
FG 493.10  
Shooting p. 98—105  
Details p. 381



Cocoon Pouf  
FG 495.01  
Shooting p. 254—257  
Details p. 382



Heta Pouf  
FG 426.01  
Shooting p. 310—313  
Details p. 383



Maio  
FG 421.00  
Shooting p. 326—327  
Details p. 385



Ocean Pouf  
FG 527.50  
Shooting p. 52—61  
Details p. 387



Quattro Pouf  
FG 518.00  
Shooting p. 136—141  
Details p. 388



Sahrai Pouf  
FG 471.01  
Shooting p. 328—331  
Details p. 389

## Sofas



Caruso  
FG 539.00  
Shooting p. 204—209  
Details p. 392



Gast  
FG 521.00/521.01  
Shooting p. 26—41  
Details p. 392—393



Gast Modular  
Shooting p. 26—41  
Details p. 392—393



Hudson Day Bed  
FG 477.00  
Shooting p. 284—289  
Details p. 394



Wilton  
FG 511.00/511.01/511.02/511.03  
Shooting p. 110—117  
Details p. 395—396



Wilton Modular  
Shooting p. 110—117  
Details p. 395—396



Winnie  
FG 483.01/483.02  
Shooting p. 158—167  
Details p. 394

## Desks



Arita Desk  
FG 520.01  
Shooting p. 42—51  
Details p. 397



Arita Console  
FG 520.02  
Shooting p. 42—51  
Details p. 397



Dante  
FG 366.00/366.02  
Shooting p. 354—359  
Details p. 397

## Tables



Twain  
FG 444.00  
Shooting p. 168—171  
Details p. 398



Artù  
FG 494.00/494.01/494.02  
Shooting p. 216—223  
Details p. 399



Blom  
FG 532.01/FG 532.02/FG 532.00  
Shooting p. 62—69  
Details p. 399



Bridge  
FG 453.01/FG 453.00/FG 453.02/FG 453.03  
Shooting p. 278—283  
Details p. 400



Dante  
FG 366.02  
Shooting p. 354—359  
Details p. 400



Doni 62  
FG 485.01  
Shooting p. 320—325  
Details p. 401

# Abacus



Doni 73  
FG 485.00  
Shooting p. 320—325  
Details p. 401



Doni 110  
FG 485.02  
Shooting p. 320—325  
Details p. 401



Myon  
FG 541.00/FG 541.01  
Shooting p. 118—129  
Details p. 401



Myon 48  
FG 541.50  
Shooting p. 118—129  
Details p. 404



Myon 80  
FG 541.51  
Shooting p. 118—129  
Details p. 404



Myon 120  
FG 541.52  
Shooting p. 118—129  
Details p. 404



Myon  
FG 541.10/FG 541.11  
Shooting p. 118—129  
Details p. 401—402



Paipu  
FG 522.01/522.00/522.02  
Shooting p. 80—87  
Details p. 402



Paipu  
FG 522.11/522.10  
Shooting p. 80—87  
Details p. 402



Quattro 26  
FG 518.52  
Shooting p. 136—141  
Details p. 405



Quattro 55  
FG 518.51  
Shooting p. 136—141  
Details p. 405



Square 34/24  
FG 465.60  
Shooting p. 266—277  
Details p. 406

## Occasional Tables



Arita  
FG 520.00  
Shooting p. 42—51  
Details p. 403



Bler  
FG 538.00/538.01  
Shooting p. 106—109  
Details p. 403



Square 52/42  
FG 465.61  
Shooting p. 266—277  
Details p. 406



Square 100  
FG 465.54  
Shooting p. 266—277  
Details p. 406



Square 140  
FG 465.56  
Shooting p. 266—277  
Details p. 406



Clubby CT  
FG 493.50  
Shooting p. 98—105  
Details p. 403



Comb 100  
FG 487.01  
Shooting p. 314—319  
Details p. 404



Comb 40  
FG 487.02  
Shooting p. 314—319  
Details p. 404

## Complements



Bak Valet Stand  
FG 440.00  
Shooting p. 258—265  
Details p. 407



Bak Valet Stand Mirror  
FG 440.01  
Shooting p. 258—265  
Details p. 407





Bak Bookcase  
FG 440.10  
Shooting p. 258—265  
Details p. 407



Loren  
FG 531.04/FG 531.05  
Shooting p. 92—97  
Details p. 407



Morgans  
FG 507.00  
Shooting p. 242—245  
Details p. 408



Otto  
FG 517.00/FG 517.04/517.05/FG 517.01  
Shooting p. 142—147  
Details p. 408



Privé A  
FG 478.01  
Shooting p. 224—231  
Details p. 409



Privé B  
FG 478.00  
Shooting p. 224—231  
Details p. 409



Privé C  
FG 478.10  
Shooting p. 224—231  
Details p. 409



Twin One Mirror  
FG 524.00  
Shooting p. 88—91  
Details p. 409



Twin Duo Mirror  
FG 524.10  
Shooting p. 88—91  
Details p. 409



Viae Valet Stand  
FG 484.50  
Shooting p. 376—378  
Details p. 409

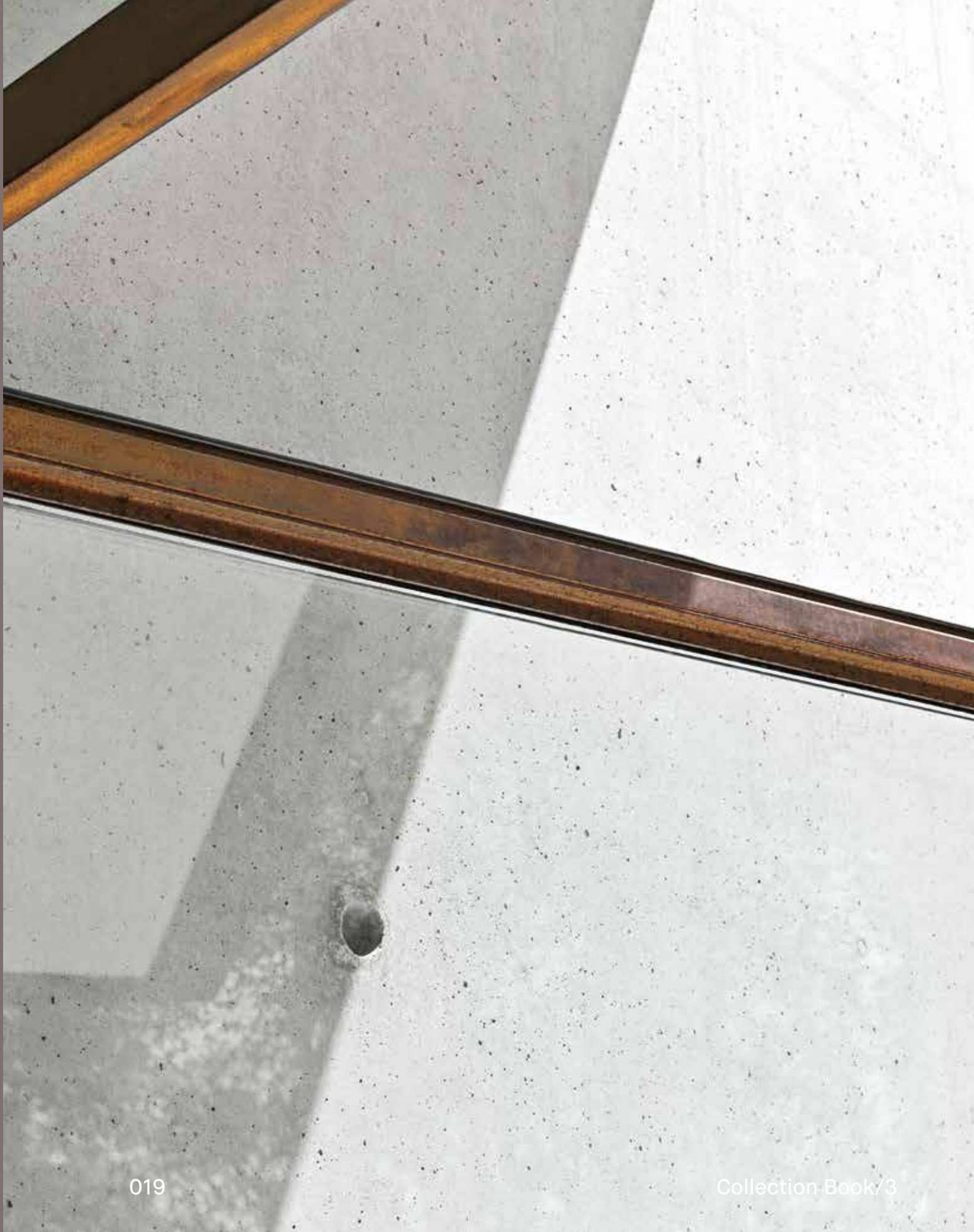

# Blyn

Oscar e Gabriele Buratti

① Blyn è una famiglia di sedute, composta da sedia e poltroncina, che esprime una sottile eleganza e si presenta con una linea asciutta ed essenziale. Interamente rivestita in cuoio, gambe incluse, Blyn è caratterizzata da uno schienale convesso imbottito e confortevole, dalle dimensioni generose. Il rivestimento in cuoio viene cucito e calzato a mano sullo scheletro in acciaio quasi come fosse un abito sartoriale. Nella poltroncina, lo schienale sagomato si congiunge ai due braccioli imbottiti per aumentare la sensazione di confort.

② The Blyn collection, comprising of a chair and an armchair, has the subtle elegance of clean, simple forms. Upholstered in saddle leather throughout, including the legs, Blyn features a comfortable and generously proportioned padded backrest. The leather upholstery is stitched and fitted by hand on the steel frame in the manner of a tailored suit. The shaped backrest of the armchair is paired with two padded armrests for superior comfort.

*chair, armchair.*



Blyn



→ Blyn / FG 533.00  
→ Blyn P / FG 533.01





→ Blyn / FG 533.00  
→ Blyn P / FG 533.01  
→ Blom 250 / FG 532.00

# Gast

Luis Arrivillaga

① Accogliente e protettivo, Gast è un divano in cui convive un'anima d'ispirazione classica tipica dei divani dei primi del '900 mescolata con l'ironia degli imbottiti degli anni '60, reinterpretato in chiave contemporanea. La voluminosità importante delle parti imbottite interne è resa più leggera dal disegno netto e lineare della struttura contenitiva esterna, caratteristiche che lo rendono unico nel suo genere. Carattere distintivo della collezione sono le cuciture, studiate minuziosamente per enfatizzare il suo disegno e la sua morbidezza.

② Welcoming and protective, Gast is a sofa in which a soul of classic inspiration, typical of the early XX century sofas, coexists with the irony of the '60s upholstered furniture, reinterpreted in a contemporary key. The substantial volume of the inner padded parts is made lighter by the clean and linear design of the outer containment structure, characteristics that make it unique in its kind. The distinctive trait of this collection of sofas is represented by the seams, accurately studied to emphasize its design and its softness.

*sofa.*

026



027



→ Quattro CT 55 / FG 518.51  
→ Quattro Pouf / FG 518.00  
→ Quattro CT 26 / FG 518.52  
→ Gast Comp 2 / FG 521.10 + FG 521.13

→ Arita CT / FG 520.00    → Gast Comp. 4 / FG 521.10  
→ Clubby Pouf / FG 493.10    + FG 521.14 + FG 521.30





Gast



→ Gast 210 / FG 521.00  
→ Gast / FG 521.15 + 521.30





→ Arita CT / FG 520.00  
→ Clabby Pouf / FG 493.10  
→ Riviera / FG 499.00  
→ Gast Comp. 7 / FG 521.10 + FG 521.14  
+ FG 521.15 + FG 521.11

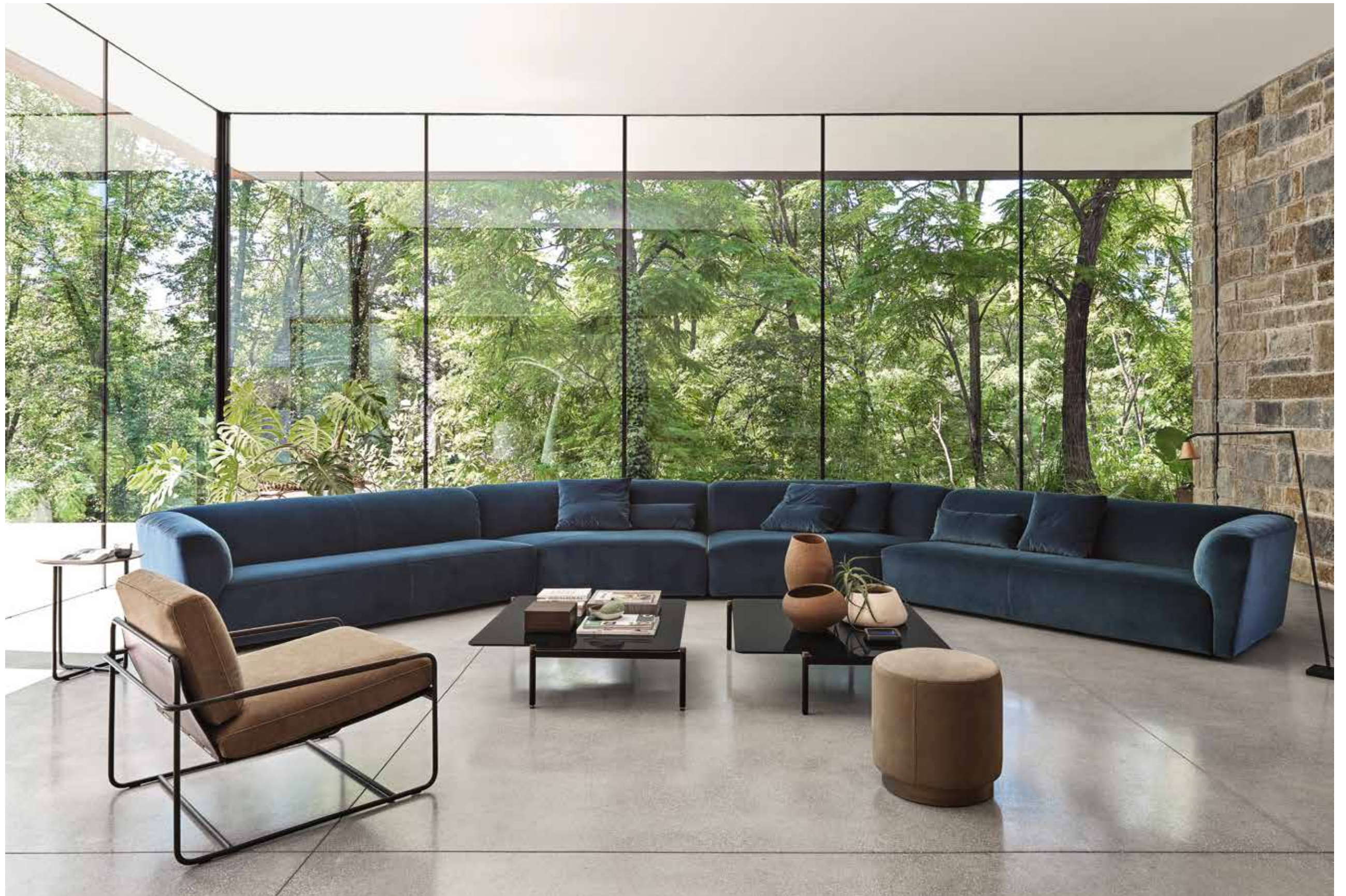

→ Arita CT / FG 520.00  
→ Clabby Pouf / FG 493.10  
→ Riviera / FG 499.00  
→ Gast Comp. 7 / FG 521.10  
+ FG 521.14 + FG 521.15  
+ FG 521.11



→ Quattro 26 / FG 518.52  
→ Gast Comp. 3 / FG 521.11 + FG 521.20



→ Gast 210 / FG 521.00



# Arita

Luis Arrivillaga

① Collezione di tre elementi composta da scrittoio, consolle e tavolino, dal design minimale e al contempo ricca di dettagli. Il disegno pulito ed essenziale del sottile piano d'appoggio acquisisce ritmo nella sua forma insolita e inaspettata. La mancanza di simmetria sia nel piano che nelle gambe, i volumi sottratti negli angoli e la struttura di sostegno sporgente, fanno di Arita una collezione unica nel suo genere e perfetta per una ricercata progettazione d'interni.

② Collection of three elements composed of a desk, a console and a coffee table, with a minimalist design yet rich in detail. The clean and essential design of the thin table top acquires rhythm through its unusual and unexpected shape. The lack of symmetry in both the top and the legs, the subtracted volumes in the corners and the protruding supporting structure, make Arita a unique collection in its kind and perfect for a refined interior design project.

*desk, consolle,  
occasional table.*

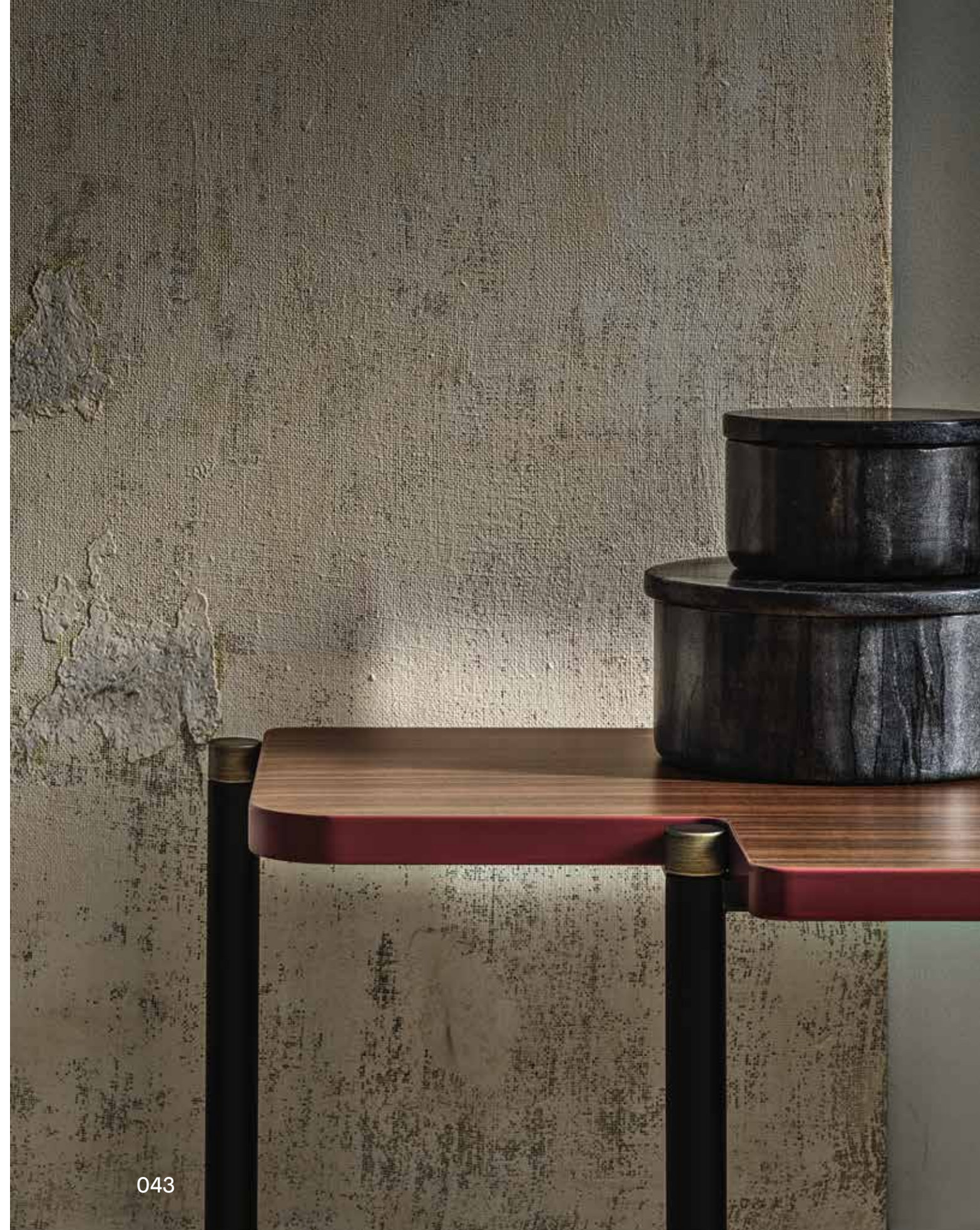

Arita Desk

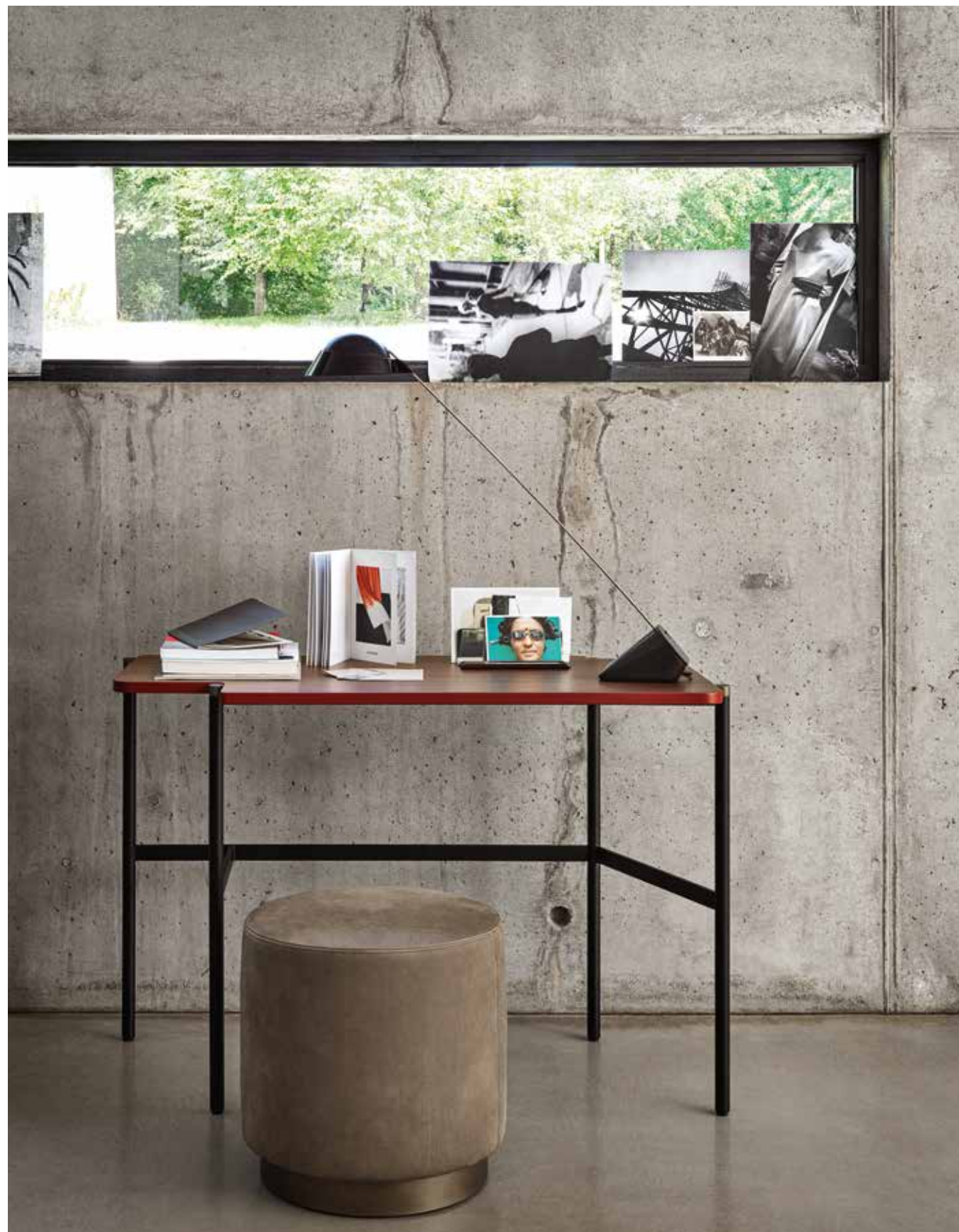

→ Arita Desk / FG 520.01

# Arita Consolle

→ Arita Consolle / FG 520.02





Arita Coffee Table





→ Arita CT / FG 520.00    → Gast comp. 9 / FG 521.10  
→ Clubby Pouf / FG 493.10    + FG 521.14 + FG 521.30

# Ocean

Werner Aisslinger

① Una poltrona lounge dallo spirito forte, capace di convivere con gli stili più diversi, un ibrido che coniuga in sé classicità e modernità. Il suo design rievoca le morbide forme delle sedute iconiche degli anni '60-'70. Ocean è una seduta che da un lato contiene e protegge con una rigida scocca sagomata, dall'altro distende e accoglie grazie alla generosa e morbida cuscinatura ergonomica. Per una soluzione di massimo comfort la poltrona viene completata con un pouf poggiapiedi. Entrambi gli elementi sono sorretti da un basamento centrale girevole in acciaio verniciato in bronzo scuro o con colore RAL su richiesta.

② A lounge chair with a strong personality that coexists happily with a wide range of styles, a hybrid combining classicism and modernity, its design recalls the soft shapes of the iconic chairs of the 60s and 70s. Ocean has a rigid moulded shell that contains and protects, accompanied by soft and generous ergonomic cushions that offer enjoyable relaxation. The armchair is completed with a footrest pouf for maximum comfort. Both elements are supported by a central revolving steel base painted in dark bronze, or in a RAL colour on request.

*lounge chair, pouf.*

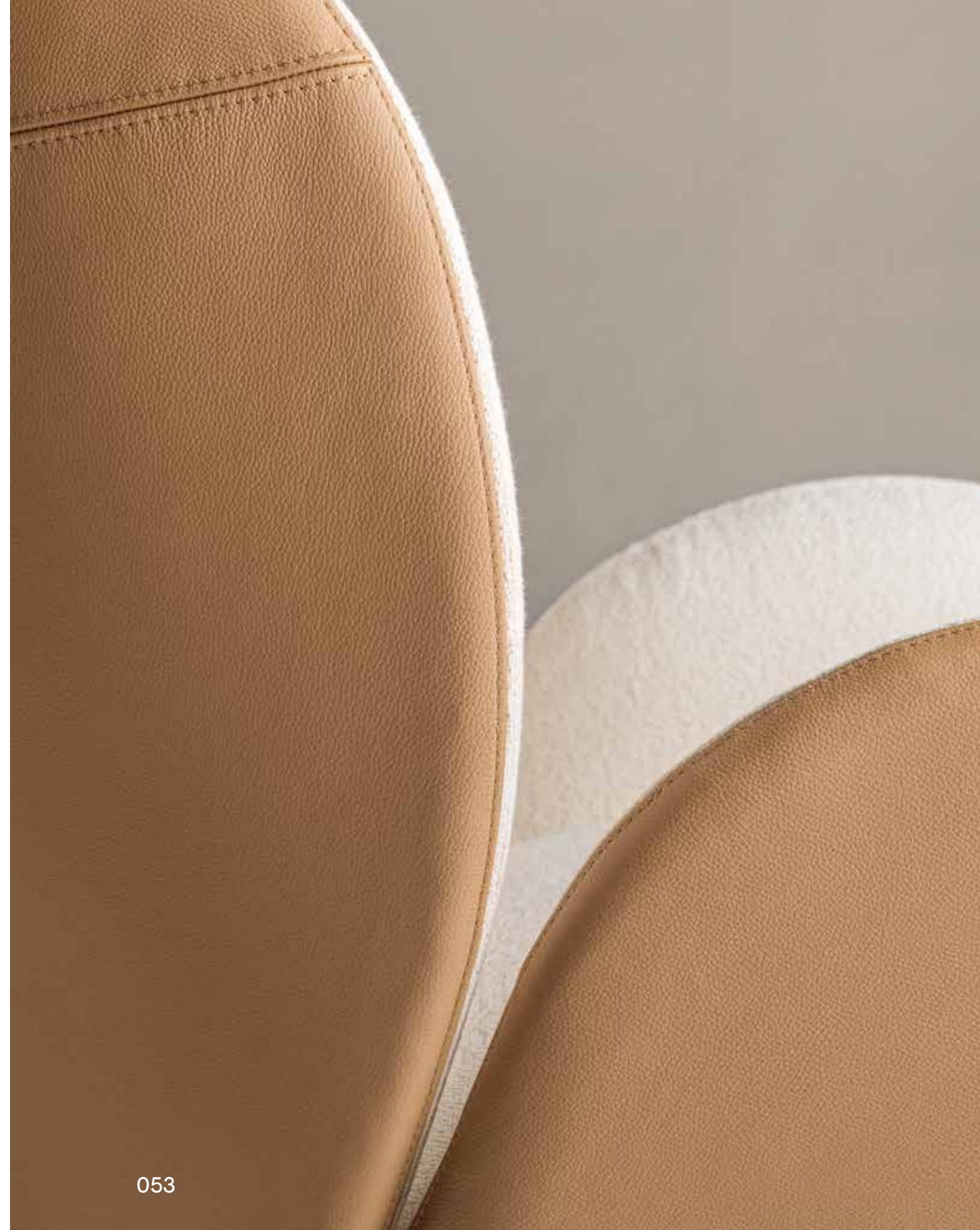

Ocean



054



055

→ Ocean / FG 527.20  
→ Bler 40 / FG 538.00

Collection Book/3



→ Ocean / FG 527.00  
→ Ocean Pouf / FG 527.50  
→ Myon 80 / FG 541.51



→ Ocean / FG 527.20  
→ Ocean / FG 527.00



→ Ocean / FG 527.20  
→ Ocean Pouf / FG 527.50  
→ Gaët / FG 521.00  
→ Myon 48 / FG 541.50  
→ Myon 80 / FG 541.51  
→ Myon 120 / FG 541.52

① Blom è una famiglia di tavoli di matrice geometrica, caratterizzata da una semplicità costruttiva e di assemblaggio affiancata da raffinatezza estetica. Le gambe, con sezione a goccia e rivestite in cuoio, sono il vero vezzo estetico nel progetto e rappresentano il cuore della lavorazione Frag. Sostengono il piano con una particolare struttura che crea uno stacco visivo tra gambe e top, quasi come se il piano fosse sospeso. Blom mostra da un lato un'anima classica con un prezioso top in marmo e dall'altro un gusto più contemporaneo proponendo un piano in vetro nero retro-verniciato.

② Blom is a family of tables with a geometric matrix, characterized by blended structural simplicity with aesthetic refinement. The legs, teardrop-shaped and covered in leather, are central to the project's aesthetic charm and epitomise Frag workmanship. They form a special structure that supports the top which appears to be detached from the legs as though suspended. Blom offers a classical image with a precious marble top, or satisfies a more contemporary taste with a top of black back-painted glass.

*table.*





→ Blyn / FG 533.00  
→ Blyn P / FG 533.01  
→ Blom 250 / FG 532.00





→ Blom P / FG 533.01  
→ Blom 220 / FG 532.02



→ Blom 200 / FG 532.01  
→ Siloe / FG 534.00  
→ Siloe P / FG 534.01



# Siloe

Oscar e Gabriele Buratti

① Siloe è una famiglia di sedute, composta da sedia, poltroncina e sgabelli dal design sobrio e armonico. L'intera famiglia si distingue per una morbida seduta sorretta da una struttura le cui le gambe si congiungono in un disegno a croce. Lo schienale si lega alla seduta con un'ironica curvatura e si estende oltre il sedile quasi a volerlo proteggere. Sedia e poltroncina sono proposte in due versioni, una con struttura in tubolare d'acciaio, severa nelle linee ma ingentilita negli spessori, e una con struttura in legno di frassino, più forte e rigorosa alla vista. Nella poltroncina le gambe si estendono fino a creare il supporto per i particolari braccioli, imbottiti nella versione in metallo, che nel loro disegno curvato sembrano voler abbracciare chi si siede. Lo sgabello, realizzato con sola struttura in legno, è disponibile in due altezze ed è completato da un poggiapiedi con inserti in acciaio inox satinato.

② Siloe is a seating family consisting of a chair, an armchair and stools of restrained and harmonious design. The entire family is distinguished by soft seat supported on a frame in which the legs are linked in a cross design. The backrest joined to the seat with an ironic curvature and extends beyond the seat as if to protect it. The chair and armchair are available in two versions, one with a tubular steel frame, austere but delicately profiled, and one with an ash wood frame that is stronger in appearance. The legs of the armchair extend to create support for the distinctive armrests, padded in the metal version, which have a curving design that seems to want to embrace the occupant. The stool, made with a wooden frame only, is available in two heights and is completed by a footrest with satin stainless steel inserts.

*chair,  
armchair, stool.*



Siloe



072



073

→ Siloe / FG 534.00  
→ Siloe P / FG 534.01

Collection Book/3

Siloe

→ Artù 180 / FG 494.01  
→ Siloe / FG 534.00  
→ Siloe P / FG 534.01



Siloe



→ Siloe W / FG 534.10  
→ Siloe PW / FG 534.11  
→ Blom 200 / FG 532.01



Siloe

→ Siloe C / FG 534.12  
→ Siloe B / FG 534.13



→ Siloe C / FG 534.12



# Paipu

Dainelli Studio

① Tavolo da pranzo disponibile in due varianti, tondo ed ovale, dall'evocativo sapore che richiama i diktat dell'architettura high-tech anni '70, dove tutti gli elementi impiantistici e strutturali venivano trasferiti sulle facciate e lasciati interamente a vista. I tubolari in acciaio curvato che compongono la base, regalano movimento e rigore al progetto, dialogando in armonico contrasto con la ricchezza del prezioso piano in marmo. Nella sua versione tonda il tavolo è sorretto da singola base con tubolari disposti a croce, mentre la versione ovale è sorretta da una doppia base con tubolari disposti a "T".

② Dining table available in two versions, round and oval, with an evocative taste that recalls the diktats of the high-tech architecture of the 70s, when all the system and structural elements were transferred to the facades and left entirely exposed. The curved steel tubes that make up the base confer movement and rigour to the project, in a dialogue of harmonic contrast with the richness of the precious marble top. In the round version the table is supported by a single base with tubes arranged in a cross, while the oval version is supported by a double base with tubes arranged in a "T" shape.

*table.*

080



081



→ Paipu 260 / FG 522.10  
→ Olimpia / FG 501.00



Paipu



→ Paipu 160 / FG 522.00  
→ Paipu 260 / FG 522.10



# Twin

Michele di Fonzo

① Famiglia composta da due specchi con disegno e dimensioni differenti, definiti da forme geometriche semplici, circolari, ovali e rettangolari, che evocano un sapore di tradizione impreziosito e attualizzato da ricercate finiture. Reminiscenza dell'eleganza anni '50, questa collezione di specchi presenta una cornice in ottone fine ed elegante che sostiene lo specchio con leggerezza. La cornice è disegnata in modo che vi sia uno spazio tra il vetro dello specchio e la cornice, conferendo un'estetica aerea, leggera e al contempo raffinata.

② Family composed of two mirrors of different designs and sizes that employ simple circular, oval and rectangular geometric shapes to embellish and update a traditional look with a sophisticated touch. This mirror collection has a stylishly delicate brass frame that offers graceful support to the mirrors and recalls the elegance of the 1950s. The frame design leaves space between itself and the mirror glass, creating a look of light and airy refinement.

*mirror.*



Twin

→ Arita Consolle / FG 520.02  
→ Twin One / FG 524.00



# Loren

Oscar e Gabriele Buratti

① Forme accoglienti e morbide caratterizzano il letto Loren in un invito al relax e al comfort. Loren è un letto con vano contenitore che si distingue per la caratteristica testata ricurva imbottita che si congiunge alla struttura, anch'essa imbottita, con un gesto accogliente e protettivo. Linee morbide nel tratto e nell'essenza, per donare una profonda sensazione di comodità. Una proposta elegante e sobria che si identifica nella sartoriale cura del dettaglio.

② The soft and warm contours of the Loren bed ensure relaxation and comfort. The Loren bed, with a lower storage compartment, features a rounded and padded headboard stylishly mounted on the base, which is also padded. The soft essential lines confer a profound feeling of comfort, with a studied elegance that is evident in the meticulous attention to detail.

*bed.*



Loren



094



→ Loren 180 / FG 531.05  
→ Bler 50 / FG 538.01

095

Collection Book/3





→ Loren 180 / FG 531.05  
→ Bier 40 / FG 538.00  
→ Bak Valet Stand Mirror / FG 440.01

# Clubby

Christophe Pillet

① La famiglia Clubby, composta da club armchair e pouf ispirati alle poltroncine dei fumoir dei circoli parigini, si arricchisce con un tavolino dalle linee tondeggianti, leitmotiv di tutta la collezione. Rifinito da un moderno piano in mdf con finitura ottone spazzolato, le proporzioni e le forme di questo tavolino lo rendono particolarmente adatto agli spazi comuni e agli utilizzi più legati al mondo del contract.

② The Clubby family, made up of club armchairs and poufs inspired by the armchairs of the fumoirs of the Parisian smokers circles, is enriched with a coffee table with rounded lines, the leitmotif of the entire collection. Finished with a modern MDF top with brushed brass finish, the proportions and shapes of this coffee table make it particularly suitable for public areas and contract settings.

*lounge chair, pouf,  
occasional table.*



Clubby

→ Clubby / FG 493.20



# Clubby

- Clubby / FG 493.20
- Clubby Pouf / FG 493.10
- Doni 62 / FG 485.01



# Clubby

- Clubby / FG 493.30
- Clubby Pouf / FG 493.10
- Clubby CT / FG 493.50



# Bler

Oscar e Gabriele Buratti

① Bler è una famiglia di tavolini fianco divano caratterizzata da semplicità costruttiva abbinata a raffinatezza estetica. Il progetto di Bler segue il concept della collezione di tavoli Blom: forme semplici che accostate tra loro compongono una famiglia di tavolini dalla matrice geometrica. La struttura e il top di Bler sono realizzati in acciaio verniciato effetto spazzolato, quest'ultimo è di forma circolare ed è sorretto da una gamba decentrata e sagomata a forma di goccia. La particolarità dei tavolini Bler è il rivestimento in cuoio della gamba, che rappresenta il cuore della lavorazione di Frag.

② The Bler family of side tables combines simplicity of construction with aesthetic refinement. The concept underlying the Blom collection of tables, is continued in the Bler project: juxtaposition of simple forms to create a family of coffee tables with a geometric matrix. Bler tops and structural elements are made of brushed-effect coated steel, with a circular top supported by an off-centre teardrop-shaped leg. As in the Blom range, the aesthetic charm of Bler tables is particularly expressed in the leg's leather upholstery, epitomising Frag workmanship.

*occasional table.*

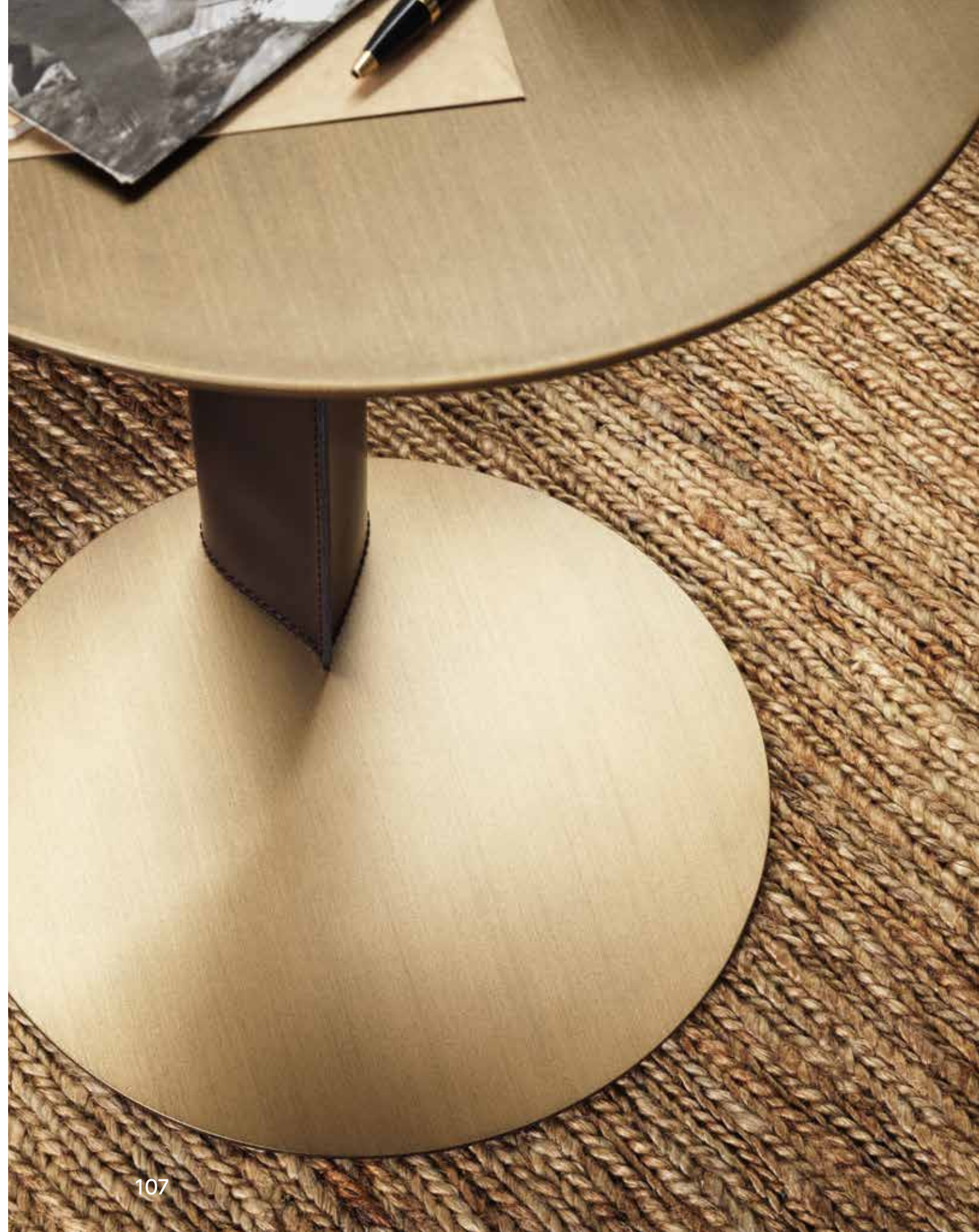



→ Bler 40 / FG 538.00  
→ Bler 50 / FG 538.01  
→ Wilton 230 / FG 511.01

# Wilton

Christophe Pillet

① È una collezione di divani chiusi ed elementi modulari leggermente imbottita e rivestita pelle o tessuto. Le forme nette della scocca definiscono il profilo squadrato di questa famiglia come fosse composta da rettangoli leggermente curvati, a creare una sorta di nido-origami. All'interno, la morbidezza dei cuscini e le dimensioni generose della seduta invitano al relax e ad una nuova forma di convivialità. Quattro sottili piedini metallici contribuiscono a rendere aerea e leggera la collezione di divani.

② Is a collection of fixed sofas and modular elements characterized by a lightly padded body that is upholstered in leather or fabric. The clear shapes of the body define the square profile of this family as if it were composed of slightly curved rectangles, creating a sort of nest-origami. The softness of the cushions and the generous dimensions of the seat invite relaxation and a new form of conviviality

*sofa.*

110



111





→ Wilton 1 / FG 511.04+FG 511.22  
→ Wilton 230 / FG 511.00



→ Square 52/42 / FG 465.61  
→ Square 140 / FG 465.56  
→ Hollow / FG 482.00  
→ Wilton 250 / FG 511.02  
→ Wilton 230 / FG 511.00  
→ Prive A / FG 478.01



→ Wilton 230 / FG 511.00  
→ Wilton 3 / FG 511.04 + 511.10  
→ Square 100 / FG 465.54  
→ Square 52/42 / FG 465.61  
→ Privé C / FG 478.10

# Myon

Oscar e Gabriele Buratti

① Una famiglia di tavoli e tavolini caratterizzata da semplicità costruttiva e da forme dalla forte matrice geometrica. La forza garbata del suo design si traduce in sottili piani circolari che si contrappongono a solide e imponenti basi cilindriche. I tavoli da pranzo, armonici nelle forme generose, sono caratterizzati dalla simmetria compositiva tra top e base. Disponibili con piano ovale e tondo, ciascuno in due dimensioni, rappresentano un invito alla convivialità. I tavolini sono invece interpretati con una base decentrata, disponibili in diverse dimensioni e altezze. L'intera famiglia è proposta con finitura laccata lucida e una dinamica palette di colori, in grado di restituire uno spirito vivace, giocoso e contemporaneo.

② A family of tables and side tables characterized by simple construction and forms with a strong geometric matrix. The graceful strength of the design translates into thin circular tops in contrast with solid and imposing cylindrical bases. The harmonious and generously proportioned dining tables display compositional symmetry between tops and bases. Available with oval or circular tops, each in two sizes, they invite conviviality. The side tables, by contrast, are interpreted with a decentralised base available in different sizes and heights. The entire family is available with a glossy lacquered finish and a dynamic colour palette that encourages a lively, cheerful and contemporary spirit.

*table, occasional table.*



# Myon

→ Ocean / FG 527.20  
→ Myon 48 / FG 541.50  
→ Myon 80 / FG 541.51  
→ Myon 120 / FG 541.52





→ Myon 260 / FG 541.11  
→ Aria / FG 545.00



→ Myon 48 / FG 541.50  
→ Myon 80 / FG 541.51  
→ Myon 120 / FG 541.52  
→ Syren FG 542.00  
→ Gast Comp. 4 / FG 521.10  
+ FG 521.14



→ Myon 240 / FG 541.10  
→ Myon 180 / FG 541.01





→ Myon 180 / FG 541.01  
→ Siloe / FG 534.00  
→ Siloe P / FG 534.01

# Syren

Oscar e Gabriele Buratti

① Syren, una poltrona che si articola in equilibrio tra morbidezza e leggerezza. La struttura interamente in tubolare metallico funge da supporto per l'ampia fascia in cuoio che avvolge e contiene gli elementi imbottiti. La comoda seduta è composta da un unico cuscino strutturale, molto voluminoso e con una forte presenza estetica. Schienale e braccioli sono invece pensati come cuscini mobili e soffici, che si adattano al corpo per una sensazione di comfort totale. La struttura in metallo si contrappone invece per leggerezza e profili sottili. Un rigore contemporaneo che trae ispirazione dal passato definisce Syren, svelando la sua personalità nei dettagli e nelle finiture.

② Syren, an armchair that balances softness and lightness. The frame, made entirely of metal tubing, supports the wide leather band that surrounds and contains the upholstered elements. The comfortable seat consists of a single structural cushion that is extremely voluminous and strong in aesthetic appeal, whereas the backrest and armrests are designed as soft mobile cushions that adapt to the body for total comfort. The lightness and slender profiles of the metal frame stand in contrast. Syren exhibits a contemporary precision that is inspired by the past and reveals its character in the details and finishes.

*lounge chair.*

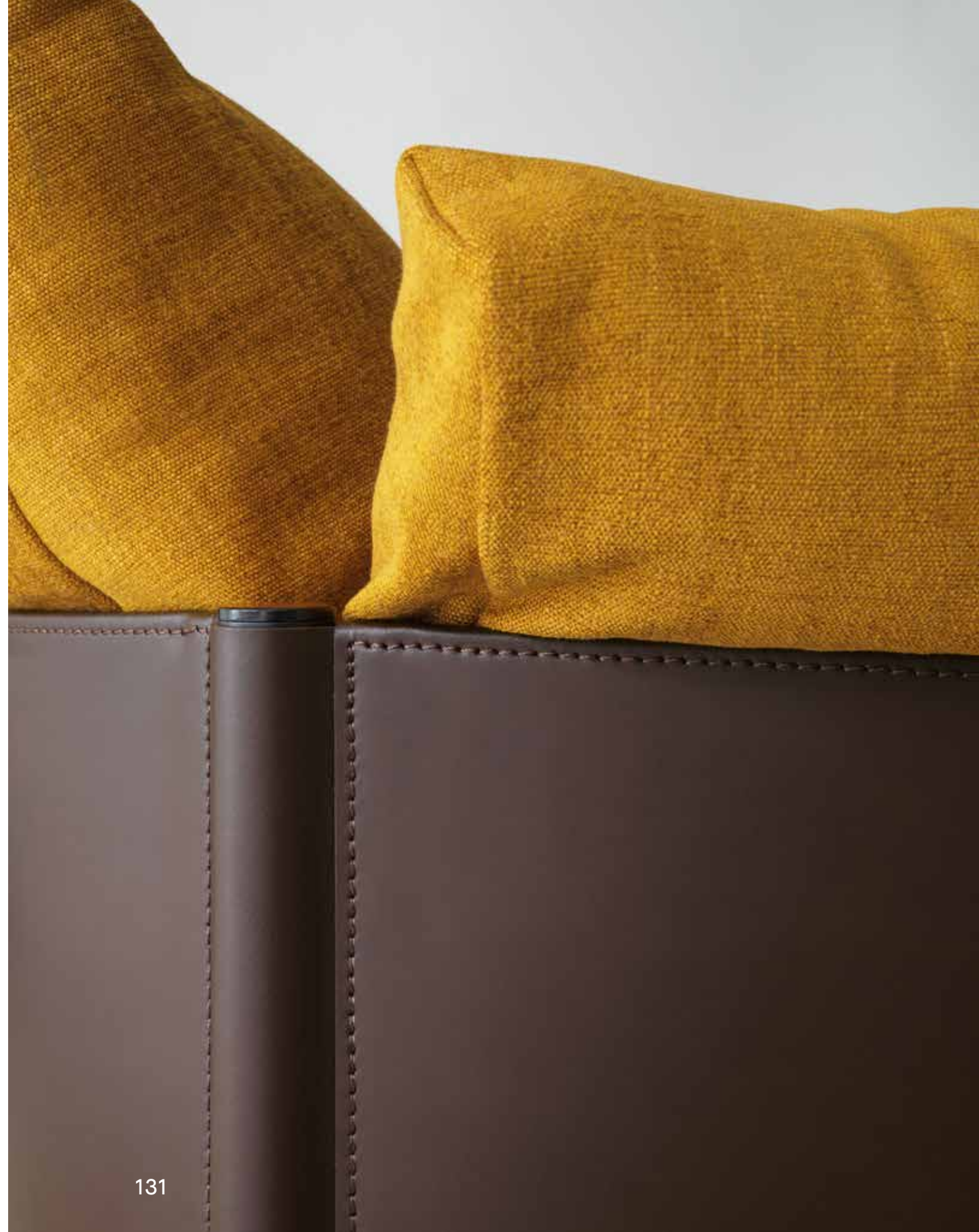



→ Syren / FG 542.00  
→ Myon 48 / FG 541.50  
→ Myon 80 / FG 541.51



→ Syren / FG 542.00  
→ Myon 80 / FG 541.51  
→ Artra CT / FG 520.00

# Quattro

Mist—o

① Un progetto di pouf e tavolini fatto di forme armoniche in cui il leitmotiv è rappresentato dal tubolare metallico curvato della base che dialoga in equilibrato contrasto con il cuscino di seduta e con i piani di appoggio. Quattro pouf è caratterizzato da una seduta generosa ed un'importante imbottitura a strati multipli che invita al relax. La seduta imbottita si rivela nel suo disegno come un cuscino decorativo sospeso nel nulla sorretto dalla leggera e minimale struttura in tubolare metallico curvato. Ad accompagnare il pouf troviamo Quattro occasional table, una serie di tavolini caratterizzati dalla stessa base in tondino metallico del pouf, su cui poggia un semplice ed elegante piano realizzato in marmo e metallo.

② A coordinated range of poufs and accent tables whose leitmotif is represented by the curved metal tubing of the base, which dialogues in balanced contrast with the seat cushion and support surfaces. Quattro pouf features a generously padded multi-layer seat that invites relaxation. The design of the padded seat gives it the appearance of a decorative cushion suspended in thin air on a light and minimal supporting structure of curved metal tubing. To complement and enhance the pouf's personality, the two designers have also designed Quattro occasional table, a series of accent tables that feature the same tubular metal base as the pouf, supporting a simple and elegant top of marble and metal.

*occasional table, pouf.*







→ Gast 240 / FG 521.01  
→ Quattro Pouf / FG 518.00  
→ Quattro CT 26 / FG 518.52  
→ Quattro CT 55 / FG 518.51  
→ Clubby Pouf / FG 493.10

# Otto

Michele di Fonzo

① Sospeso da terra e sorretto da una struttura dalle linee delicate, il letto Otto si distingue per il rivestimento totalmente in pelle e per il particolare disegno fluido e avvolgente della testata imbottita pensata per facilitare i momenti di lettura. Caratteri distintivi sono la sinuosa curva che raccorda testata e giroletto, e il segno netto orizzontale al centro della testata che raccoglie e arriccia la pelle del rivestimento accentuando il senso di comfort.

② Suspended from the ground and supported by a structure with delicate lines, the Otto bed stands out for its full leather upholstery and for the particular fluid and enveloping design of the padded headboard, conceived to ease the moments dedicated to reading. Distinctive features are the sinuous curve that connects the headboard to the bed frame, and the sharp horizontal stroke in the center of the headboard that gathers and wrinkles the leather of the upholstery, accentuating the sense of comfort.

*bed.*







→ Otto 180 / FG 517.05  
→ Quattro Pouf / FG 518.00  
→ Quattro CT 55 / FG 518.51  
→ Clubby Pouf / FG 493.10



→ Otto 180 / FG 517.05



# Bella

G. & R. Fauciglietti

① Deve il suo fascino senza tempo alla elegante figura slanciata e al profilo garbato, che ne fanno il perfetto archetipo della seduta in pelle. Lo schienale, realizzato in uno speciale acciaio armonico flessibile con memoria, aggiunge movimento in un equilibrio perfetto tra estetica e comodità.

② Owes its timeless charm to its elegant, slender silhouette and its graceful profile, which make it the perfect archetypical leather chair. The back, in special flexible spring "memory" steel, conveys dynamism to a perfect balance between beauty and comfort.

*chair, stool,  
armchair.*



Bella Chair



→ Bella / FG 320.01



→ Bella H / FG 320.00

Bella Chair

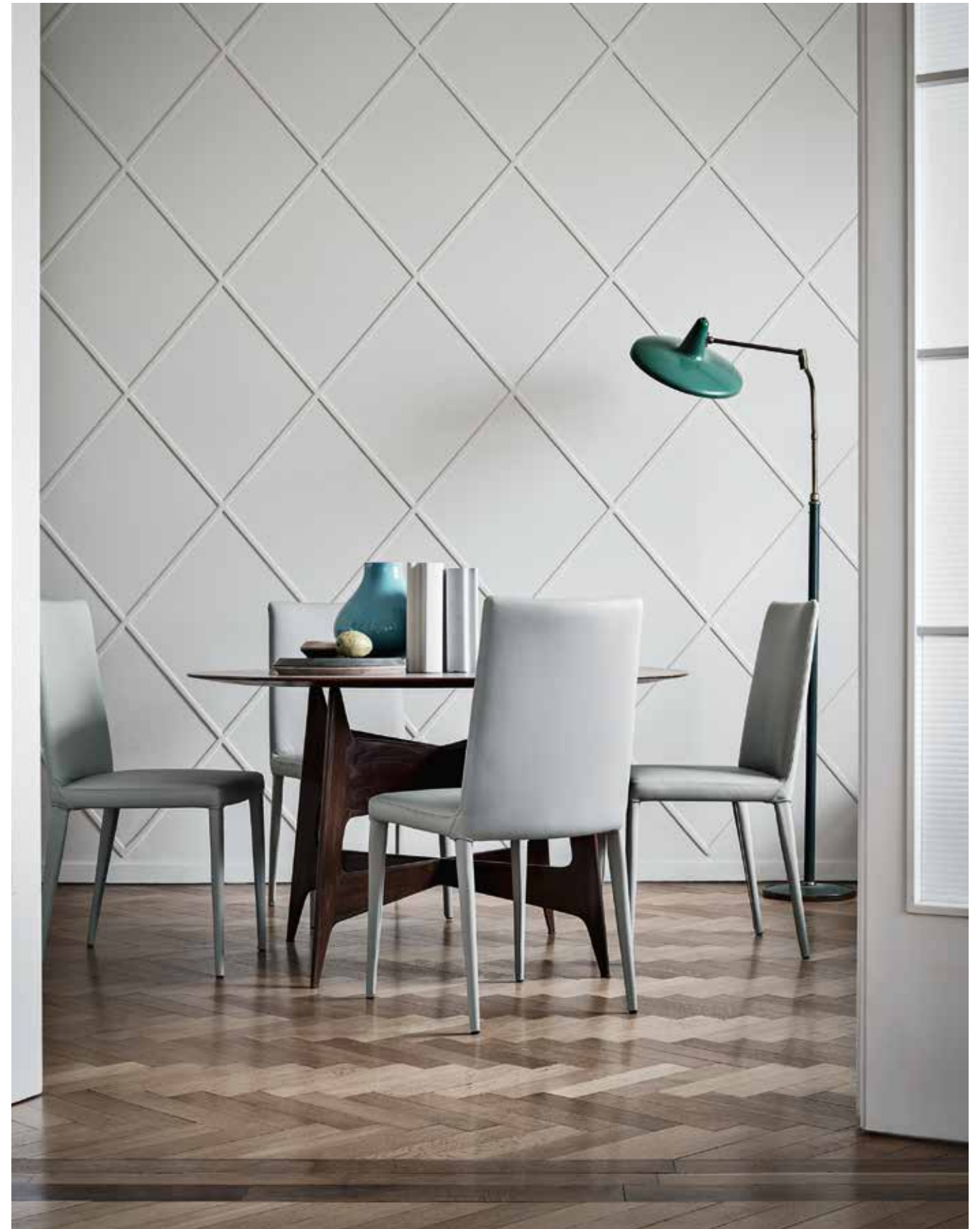

→ Bella GP / FG 320.04



Bella stool



→ Bella C / FG 320.15  
→ Bella B / FG 320.16

# Bella Armchair

→ Bella P / FG 320.03



# Winnie

Mist—o

① È una collezione composta da divano e poltrona, caratterizzati da forme generose e imbottiture che invitano al relax. La scocca rivestita in pelle o tessuto disegna seduta e schienale, curvandosi a formare una sorta di nido. Al suo interno un unico cuscino come schienale rivestito in pelle o tessuto curvato a formare una U, definisce uno spazio intimo, un rifugio, in cui sprofondare viziati dalla preziosa morbidezza del materiale.

② Is a collection featuring a sofa and an armchair notable for their generous form and padding which invites relaxation. The shell is upholstered in leather or fabric, while the design of the seat and back curve to form a nest shape. Inside this is a single U-shaped cushion as a backrest, upholstered in leather or fabric. Winnie is a refuge, a private space in which to nestle, surrounded by the comforting softness of the materials.

*sofa, lounge chair.*





→ Comb 100 / FG 487.01  
→ Winnie Sofa 240 / FG 483.02  
→ Winnie / FG 483.00







Winnie





→ Winnie / FG 483.00  
→ Doni 62 / FG 485.01

# Twain

Gordon Guillaumier

- ① Riprende linee e concetti alla base del funzionalismo, principi di sobrietà e semplicità descritti in questo secretaire contemporaneo attraverso una struttura in metallo lineare impreziosita da ripiani e dettagli in pelle.
- ② Revisits the lines and concepts at the root of functionalism, principles of sobriety and simplicity described in this contemporary secretary desk through a linear metal structure embellished with leather shelves and details.

*desk.*



Twain

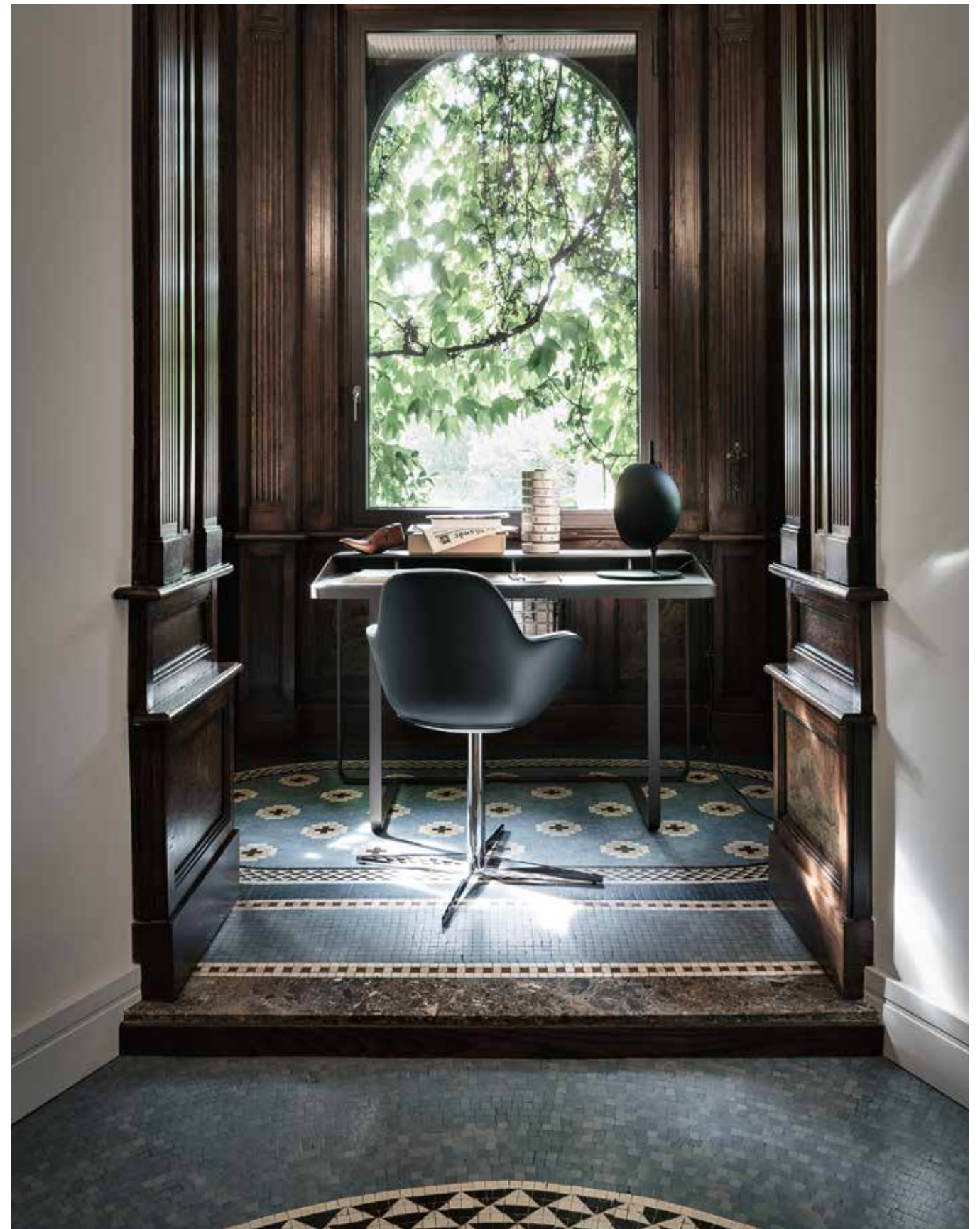

→ Twain / FG 444.00

# Doa

Alessandro Dubini

① Si configura come la classica seduta con struttura in legno a vista, un arredo intramontabile in grado di valorizzare differenti ambienti domestici. La base e le gambe affusolate sostengono il cuscino di seduta e lo schienale, disegnando una silhouette armoniosa ed accogliente.

② Is a classic chair with a visible wooden frame, a timeless piece that will enhance many different rooms of the home. The base and tapered walnut legs support the seat and back cushioning, creating a harmonious, welcoming silhouette.

*chair, armchair.*



Doa



→ Doa P / FG 464.02  
→ Doa / FG 464.03

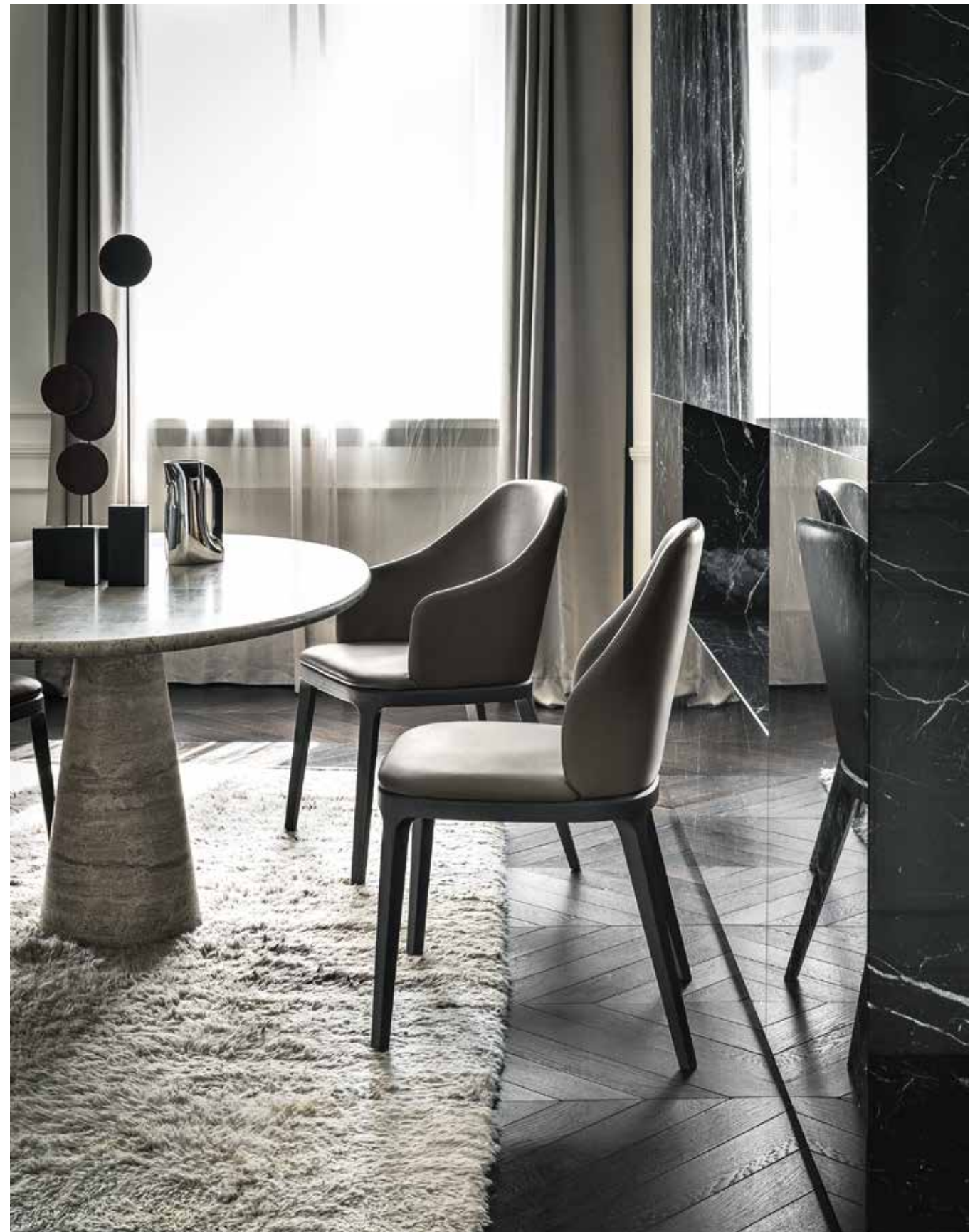



## 2. Corporate

## *Identity*



## Azienda

① È ormai dal 1921 che l'azienda, forte di una lunga tradizione familiare, tratta il cuoio e la pelle con cura, competenza ed esperienza. Il bagaglio culturale e tecnico di Frag è stato nel tempo affiancato da una continua ricerca orientata, da un lato, verso l'acquisizione di un'expertise nella lavorazione di altri materiali, dall'altro, verso forme sempre nuove, dedicati sia al mercato residenziale che al contract. Sono questi gli elementi che oggi definiscono la collezione di Frag, dando vita ad un catalogo stilisticamente coerente con la sua lunga storia produttiva, fatto di linee nuove e materiali senza tempo.

② Frag has almost a century's worth of experience of treating leather and saddle leather with care and skill, with a strong family tradition dating back to 1921. Over the years, Frag has constantly pursued cultural and technical advancement through ongoing research oriented towards the acquisition of expertise in the processing of other materials and towards new forms for both the residential and contract markets. Frag's current collection, as displayed in a catalogue of new lines and ageless materials that is stylistically consistent with its long production history, reflects these aims.



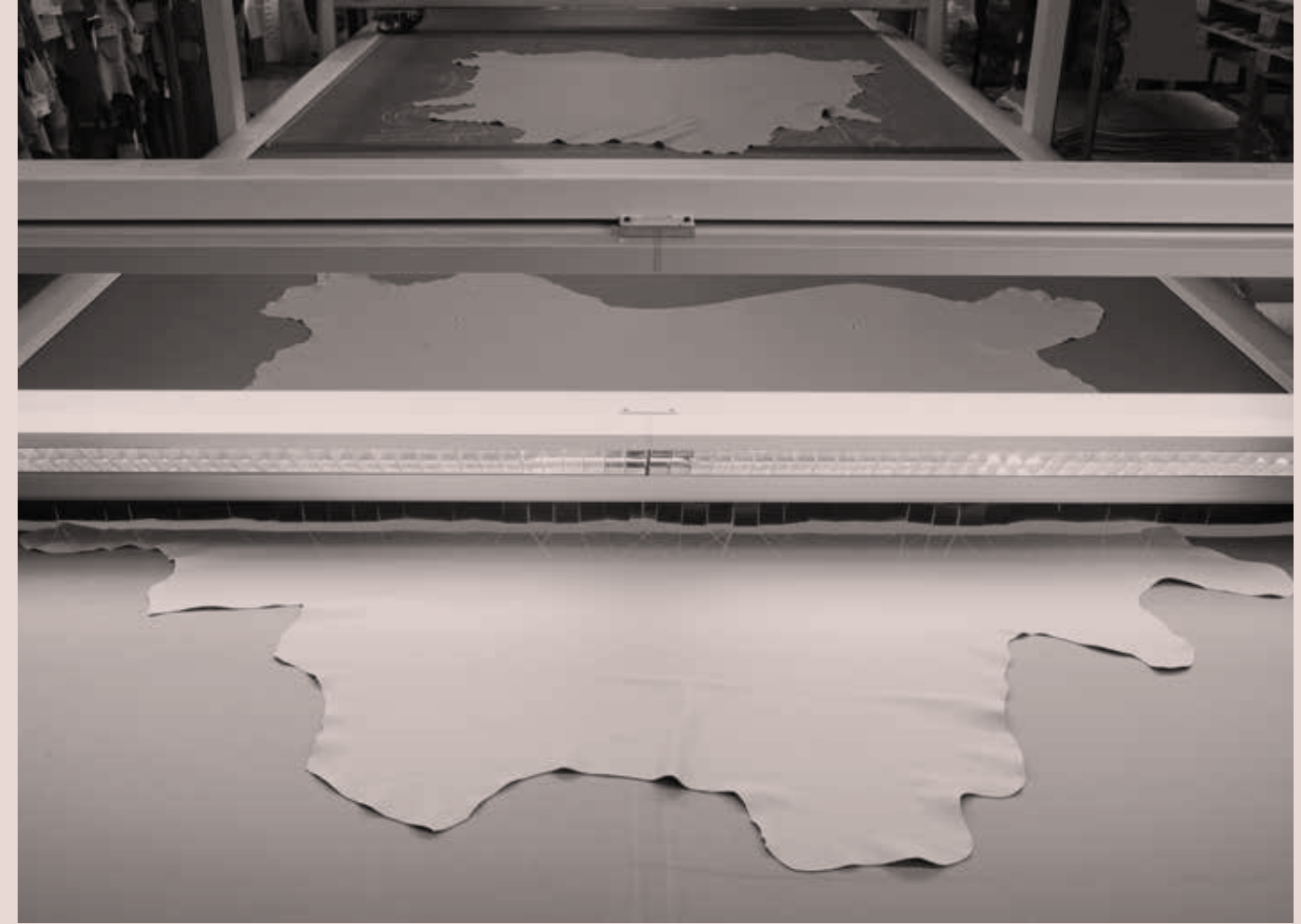





## Bespoke

① L'ampia proposta prodotti e collezioni a catalogo riesce a creare non solo degli oggetti di arredo ma delle vere e proprie suggestioni estetiche per un universo abitativo raffinato e contemporaneo. La grande varietà di pellami – oltre 100 tipologie a catalogo – e tessuti disponibili è stata affiancata da una ricerca su materiali. Rivestimenti e materiali riescono vestire i prodotti di Frag secondo i gusti e gli stili più differenti. Inoltre, l'azienda offre un servizio dedicato al contract che consente di personalizzare gli oggetti a catalogo e a realizzare prodotti completamente su misura.

② The products and collections available in the extensive catalogue are more than items of furniture; they represent genuine aesthetic possibilities for a refined and contemporary lifestyle. With over 100 types of leather and numerous fabrics available in the catalogue, research into materials continues. The wealth of coverings and materials means that Frag products can be upholstered in a wide variety of tastes and styles. Moreover, the company offers a specialised contract service for full personalisation of catalogue items.



## Showroom

① Nel cuore di Milano, lo showroom Frag è uno spazio di oltre 300 metri quadri dove viene messo in scena il lifestyle aziendale in un susseguirsi di spazi espositivi ininterrotti e fluidi. Inserito al piano terra di un palazzo storico, ospitato all'interno del concept store di Mo.1950, lo showroom si affaccia sul panorama urbano con otto vetrine, mettendo in dialogo gli spazi interni del negozio e il contesto che lo accoglie. Un dialogo che consente alla luce naturale di penetrare lo spazio e di illuminare gli ambienti espositivi creando suggestivi giochi di luci ed ombre. Uno spazio funzionale ed immersivo, che svela l'identità del brand, in un continuum visuale e dinamico. Le stanze, allestite con i prodotti più iconici della collezione, mettono in mostra la maestria nella lavorazione di cuoio e pelle tipica della produzione Frag. La scelta dei prodotti in esposizione, i materiali e lo studio attento delle ambientazioni offrono al visitatore la possibilità di vivere un'esperienza basata sul concetto di casa.

② Frag's showroom, in the heart of Milan, occupies a space of almost 300 square metres in which corporate lifestyle is represented in a succession of uninterrupted and fluid exhibition spaces. Located on the ground floor of a historic building, housed in the Mo.1950 concept store, the showroom has eight windows looking out on the urban landscape and creating a dialogue between its interior spaces and the surrounding area. Natural light floods in to illuminate the display areas with enchanting plays of light and shade. The functional and immersive space reveals the identity of the brand in a dynamic and visual continuum. The collection's most iconic items are positioned throughout the rooms to showcase the craftsmanship in leather and saddle leather that typifies Frag products. The choice of products on display, the materials chosen and the carefully designed settings offer visitors an experience based on the concept of the home.

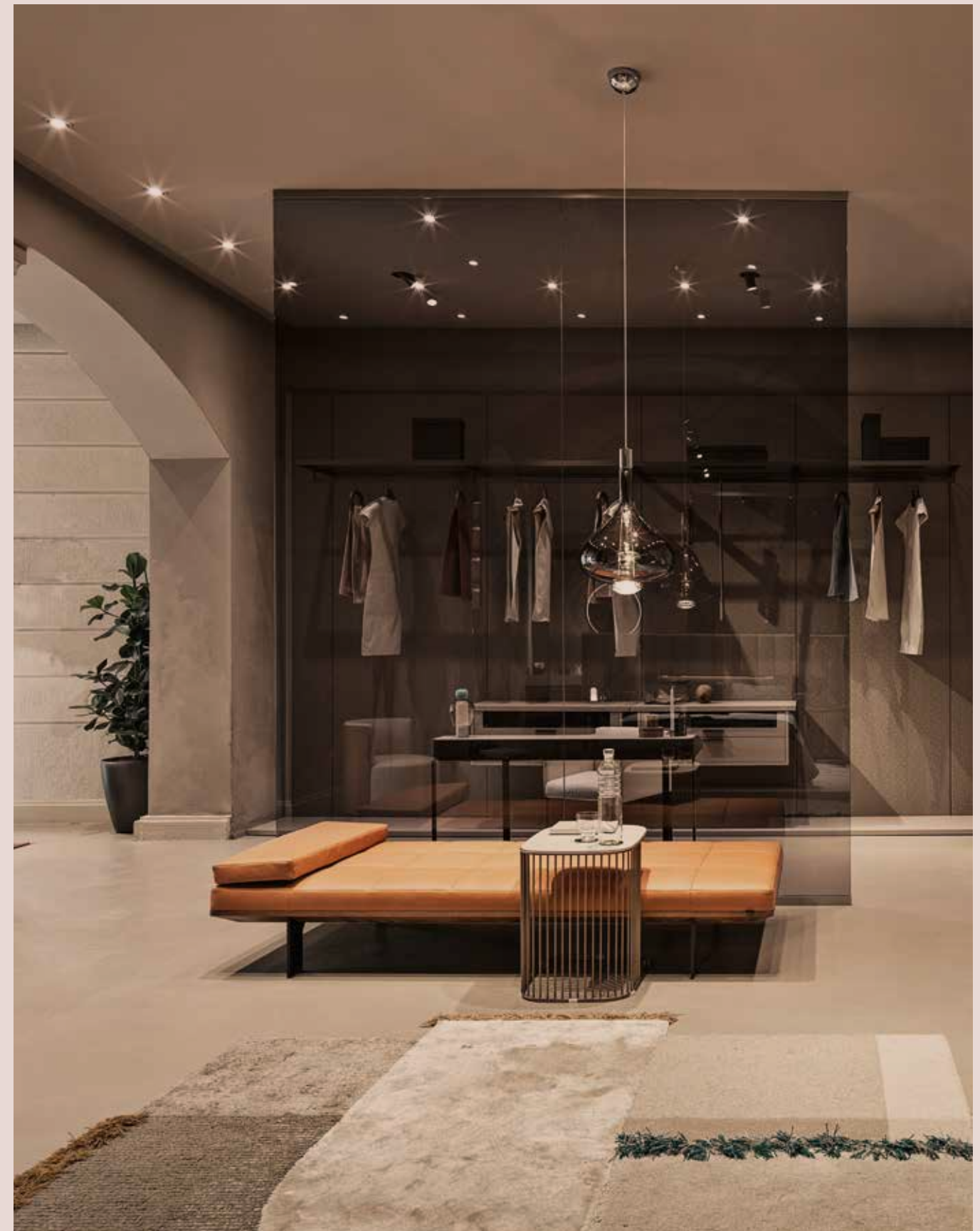







## Contract

① Il know how quasi centenario e le tecnologie introdotte nella lavorazione dei materiali vengono messe a disposizione di architetti, decoratori, interior designers e developers per offrire un servizio specifico dedicato alle realizzazioni contract. La solida esperienza di Frag e la sua struttura versatile garantiscono un supporto concreto in tutti gli stadi di realizzazione, dalla fase progettuale ai servizi post vendita, assicurando un servizio contract dedicato, su misura ed estremamente professionale.

② The expertise gained by Frag in almost a century of business and the manufacturing technologies employed are made available to architects, decorators, interior designers and developers as a service deliberately geared towards achieving successful contract completion. Frag's significant experience and versatile structure ensure a commitment to consistent support in all stages of the process, from initial design to post-sales, guaranteeing a dedicated, tailored and highly professional contract service.

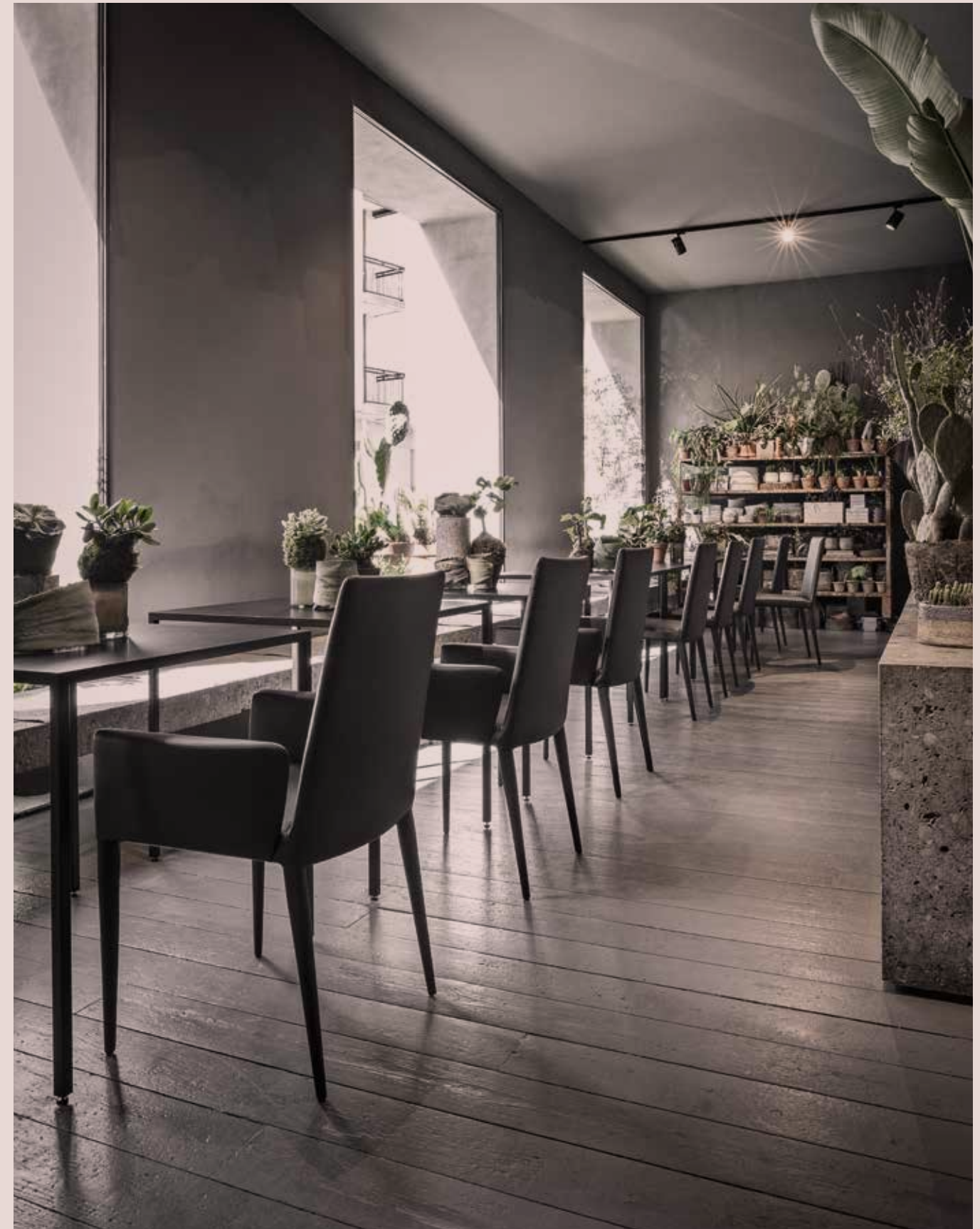





## 4.Products

## *Collection*





# Caruso

Dainelli Studio

① Misurata eleganza e comfort caratterizzano la chaise longue Caruso, in un equilibrio ideale fra purezza geometrica e comodità. Un design che mette in dialogo una sottile scocca rigida rivestita in cuoio, piegata a contenere il cuscino e il poggiatesta, con la particolare struttura in tubolare d'acciaio, asimmetrica e minimale. Caruso è modellato seguendo le naturali linee del corpo e pensato per accogliere i momenti di riposo quotidiano. Una seduta classica proposta con linee e proporzioni fortemente contemporanee, elemento votato alla cultura del relax.

② The Caruso chaise longue displays restrained elegance with a perfect balance of comfort and geometric purity. Its design creates a dialogue between a thin rigid shell covered in saddle leather, which is folded to contain the cushion and the headrest, and the distinctive tubular steel frame, asymmetrical and minimal. Caruso is modelled to accommodate the natural lines of the body for satisfying moments of rest. Classic seating with highly contemporary lines and proportions, designed with relaxation in mind.

*chaise longue.*

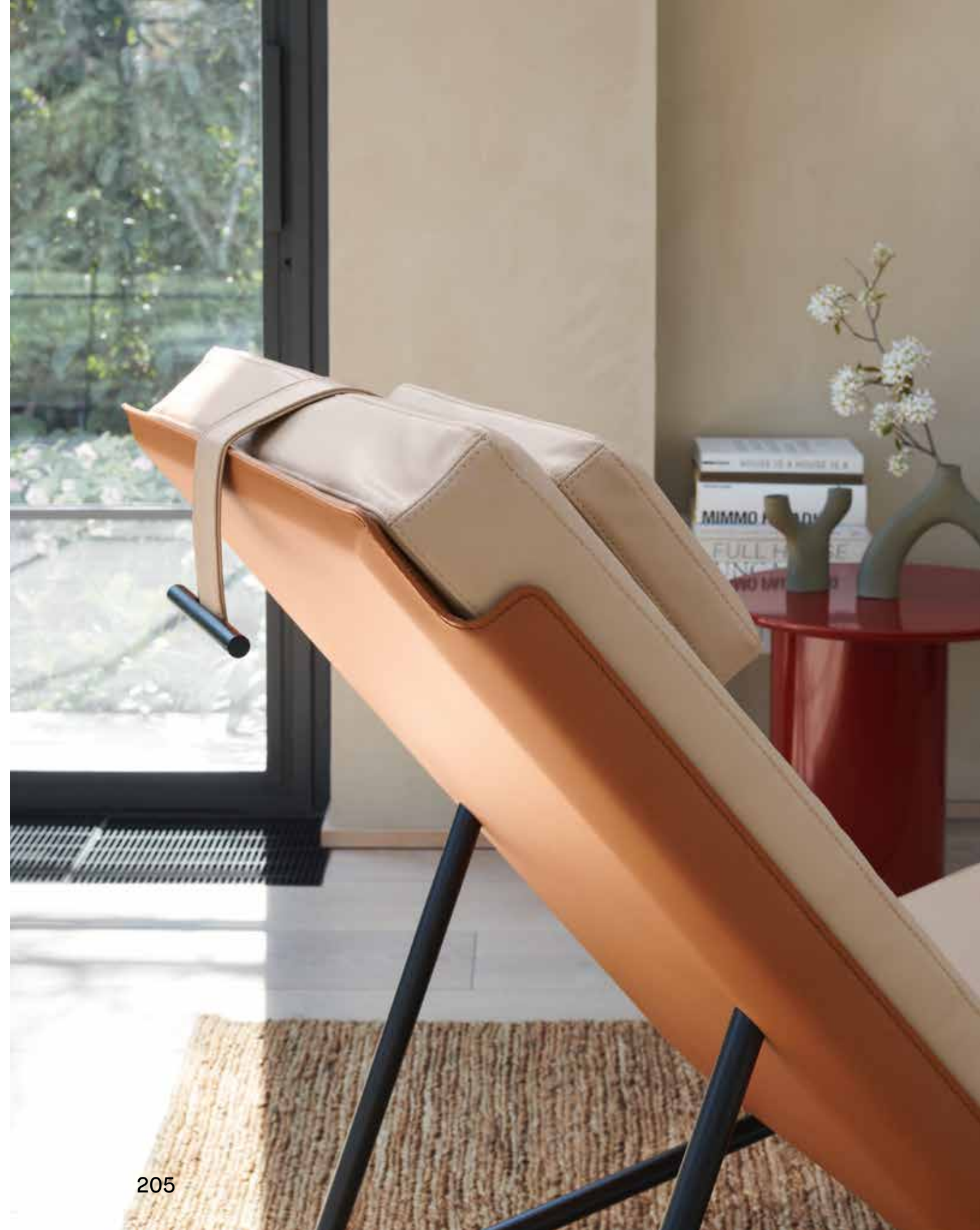



→ Caruso / FG 539.00

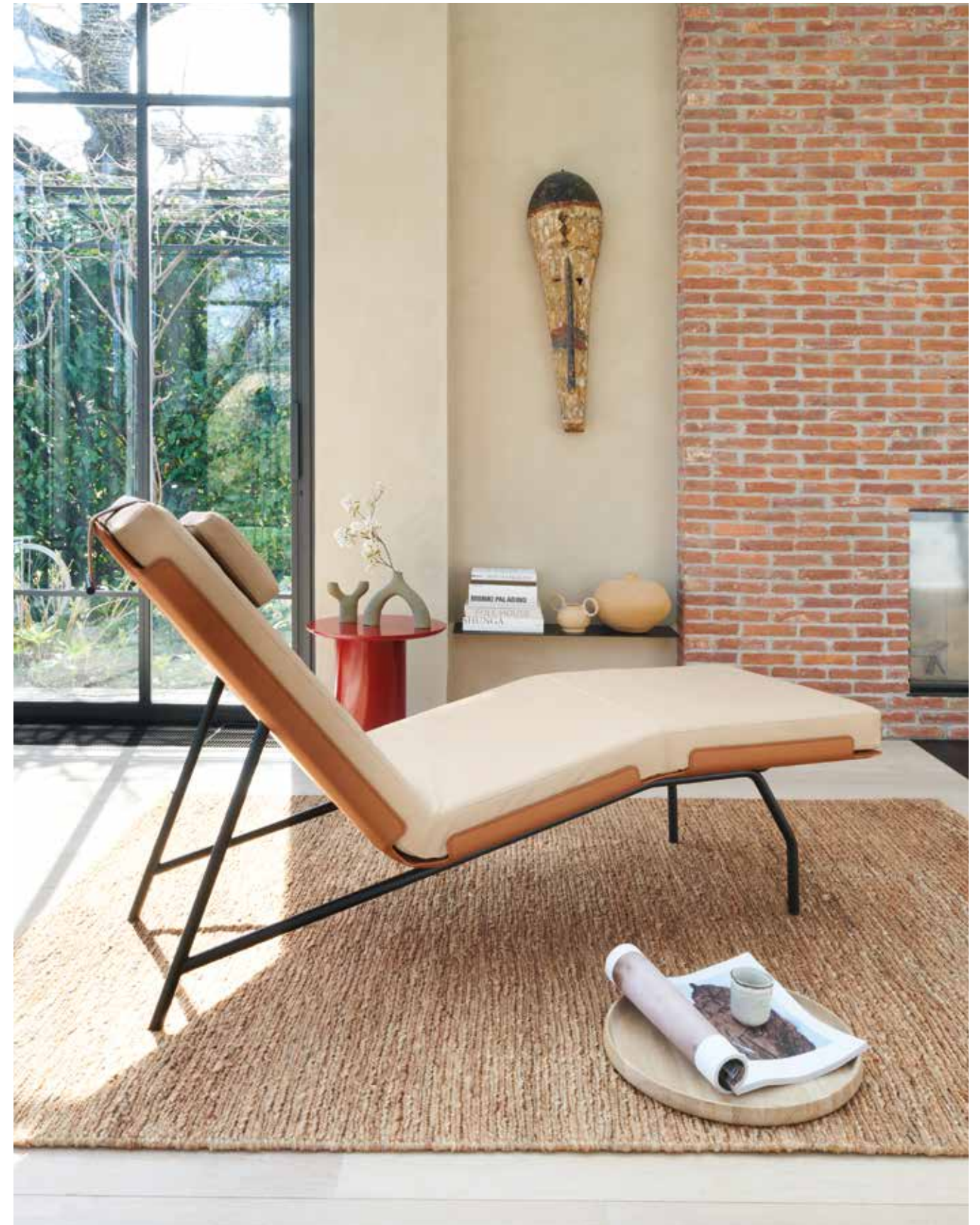

→ Caruso / FG 539.00  
→ Myon 48 / FG 541.50





→ Caruso / FG 539.00  
→ Myon 48 / FG 541.50

# Elf

Gordon Guillaumier

① La famiglia di sedie, poltroncine e sgabelli mantiene un profilo rigoroso senza rinunciare al comfort, grazie alla morbida imbottitura e allo schienale flessibile, dando vita ad un oggetto fatto di nuove sinuosità dal gusto estremamente contemporaneo.

② Is a collection of chairs, armchairs and stools, with a clean-cut profile that doesn't compromise on comfort, thanks to the soft upholstery and flexible back, which produce a sinuous, curved item with a particularly contemporary flavour.

*chair,  
armchair, stool.*



→ Elf / FG 497.00



212

→ Elf / FG 497.00  
→ Elf P / FG 497.01



213

Collection Book/3



# Artù

Michele di Fonzo

① Archetipo del tavolo da pranzo rotondo, è un oggetto dalle forme importanti e dal carattere sontuoso, dedicato ai dining più lussuosi e alle sale riunione più ricercate. La base del tavolo, rivestita in morbida pelle e impreziosita da un basamento e da profili in ottone brunito, dichiara immediatamente lo statement di questo oggetto dalla forte personalità.

② The archetypal round dining table, its impressive shape and distinguished appearance make it suitable for the most luxurious dining areas and elegant meeting rooms. The base of the table, upholstered in soft leather and enhanced by a burnished brass base and profiling, marks this out as a piece with a strong personality that makes an immediate statement.

*table.*





→ Artù 160 / FG 494.00  
→ Lazy Susan / AC 494.00

→ Artù 160 / FG 94.00



→ Artù 180 / FG 494.01  
→ Siloe / FG 534.00  
→ Siloe P / FG 534.01





# Privé

Christophe Pillet

① Unisce ispirazioni anni '60, linee contemporanee e materiali preziosi, facendo della cura per il particolare il proprio vezzo caratteristico. Questa collezione di mobili contenitori si compone di elementi di grande matericità - come la cassa in noce, i ripiani in vetro e i dettagli in pelle del top e degli accessori - insieme ad un disegno fatto da spessori sottili, bordature a 45° e alla leggerezza dei quattro sottili piedini in tondino acciaio scuro spazzolato.

② Is the fruit of research on the fine dialectics between the softness of leather and the warmth of wood, narrated through a clean and essential style, and through the care and value of details that distinguish this evocative collection.

*cupboard, sideboard.*



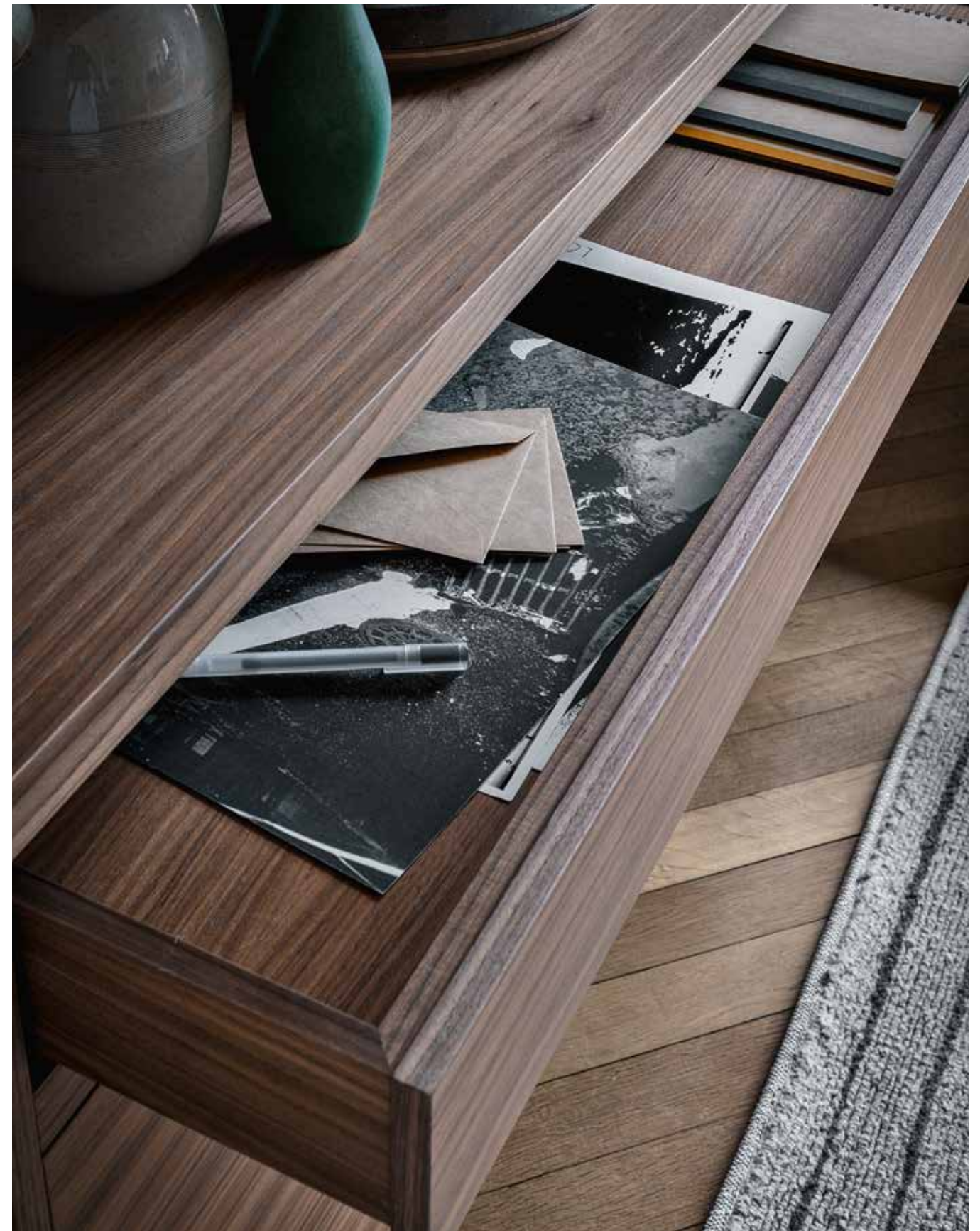



→ Privé A / FG 478.01  
→ Maio / FG 421.00

Privé

→ Privé A / FG 478.01  
→ Privé B / FG 478.00



# Ponza

Gordon Guillaumier

① Nasce da un lavoro di ricerca sulla fine dialettica tra la morbidezza della pelle e il calore del legno, narrato attraverso uno stile pulito ed essenziale, la cura e il pregio dei particolari che caratterizzano questa famiglia evocativa.

② Is the fruit of research on the fine dialectics between the softness of leather and the warmth of wood, narrated through a clean and essential style, and through the care and value of details that distinguish this evocative collection.

*chair, stool.*







→ Ponza GP / FG 405.07



# Olimpia

Dainelli Studio

① È una seduta che unisce estetica e funzione, in un gioco in cui la struttura metallica sostiene e ricalca la silhouette di seduta e schienale senza quasi toccarla. La scocca è impreziosita da impunture capitonné confermando la personalità decorativa e contemporanea di Olimpia.

② Combines aesthetics and functionality, with a metal frame that supports and traces the outline of the seat and backrest almost without touching it. The body is embellished with capitonné stitching which gives it the signature decorative and contemporary Olimpia style.

*chair, armchair.*





# Olimpia



→ Olimpia P / FG 501.01  
→ Olimpia / FG 501.00



# Morgans

Dainelli Studio

① Una libreria che utilizza come montanti due barre verticali a sezione rettangolare accostate che incrociano e fissano cinque barre orizzontali su ogni lato. Il disegno degli elementi metallici, dallo stile quasi industriale e costruttivista, crea un affascinante contrasto con la ricercatezza della finitura in ottone brunito e con il rivestimento in prezioso cuoio delle mensole, creando un oggetto dal carattere peculiare e dall'estetica decorativa.

② Is a bookshelf that uses two vertical rectangular bars placed side by side that cross and fix five horizontal bars on each side. The design of the metallic elements, with an almost industrial and constructivist style, creates a fascinating contrast with the refinement of the burnished brass finish and the precious leather covering of the shelves, creating an object with a peculiar character and a decorative aesthetic.

*bookshelf.*



→ Olimpia P / FG 501.01  
→ Twain / FG 444.00  
→ Morgans / FG 507.00



Morgans



→ Morgans / FG 507.00



① Gioca con la commistione dei materiali, mixando la pelle o il cuoio utilizzati per seduta e schienale con il metallo e il legno utilizzati per le gambe. Oggetto dal carattere disegnato ed elegante, questa seduta dal carattere forte si adatta ad ambienti contract più formali come a contemporanei paesaggi domestici.

② Plays with the blending of materials, combining leather or saddle leather used for the seat and backrest with the metal and wood used for the legs. An object with an elegant design, this chair with its strong features suits formal public spaces as well as contemporary home settings.

*chair, armchair.*





→ Iki W / FG 333.05  
→ Iki PW / FG 333.06



# Riviera

Dainelli Studio

① È una lounge armchair in cui sono leggibili sia richiami modernisti, per l'utilizzo del tubolare metallico, sia un'impronta contemporanea e decorativa, per l'utilizzo della finitura ottone brunito graffiato e l'accostamento tra la pelle o tessuto dei cuscini ed il cuoio di seduta e schienale.

② Is a lounge chair which displays hints of modernism in its use of metallic tubing, while a contemporary, decorative influence is provided by the burnished brass finish and the combination of the fabric or leather-upholstered cushions and the saddle leather on the seat and back.

*lounge chair.*



Riviera



→ Riviera / FG 499,00

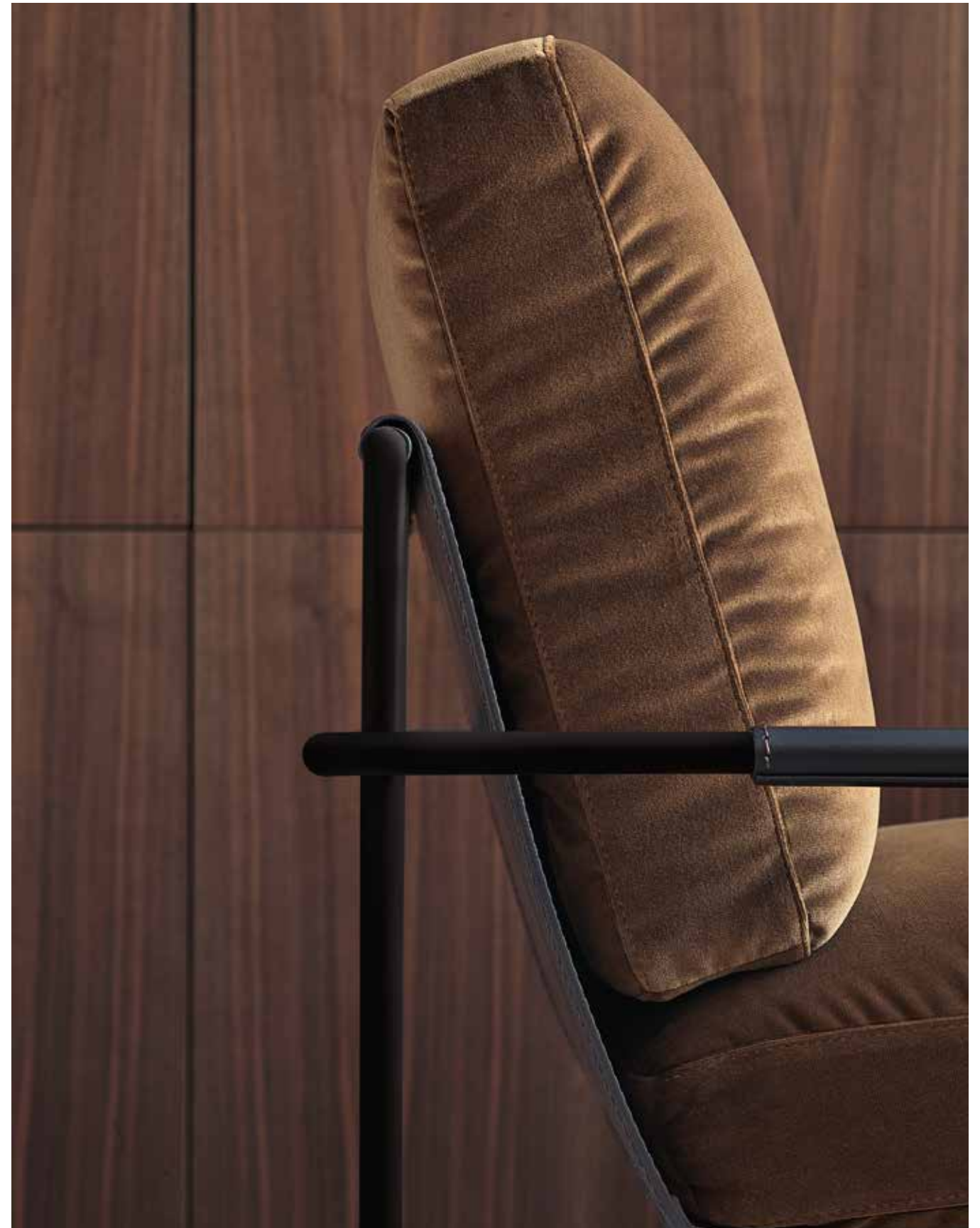

# Cocoon

Dainelli Studio

① È una collezione composta da poltrona lounge con poggiatesta, fatta di forme avvolgenti, armoniche, equilibrate e da sapienti accostamenti materici: perfetto connubio tra formalismo estetico e comfort, testimonia una grande abilità nel mixare e lavorare materiali e rivestimenti differenti.

② Is a collection featuring a lounge chair with a footrest, combining enveloping, harmonious, balanced lines with skilfully paired materials: a perfect marriage of aesthetic formalism and comfort, evidence of an ability to blend and work with different materials and upholsteries.

*lounge chair, pouf.*







→ Cocoon / FG 495.00  
→ Cocoon Pouf / FG 495.01  
→ Clubby Pouf / FG 493.10

# Bak

Ferruccio Laviani

① Gioca con contrasti materici ponderati dati dall'accostamento della struttura in tubolare metallico e dettagli in pelle mixati con piani in legno – per tavolo, tavolini e libreria – e morbide imbottiture – servomuto e panca con cuscino –, declinando una famiglia composta da arredi e complementi dedicati alla zona notte e agli spazi living più ricercati.

② Plays with well thought-out material contrasts resulting from the pairing of the tubular metal structure and leather details combined with the wooden shelves – for table, accent tables and bookcase – and with soft padding – for the valet stand and bench with cushion – that conjugate a collection of furniture and accessories dedicated to the bedroom and to the most refined living spaces.

*valet stand, bookcase.*



Bak Valet Stand



Bak Valet Stand



→ Bak Mirror / FG 440.01

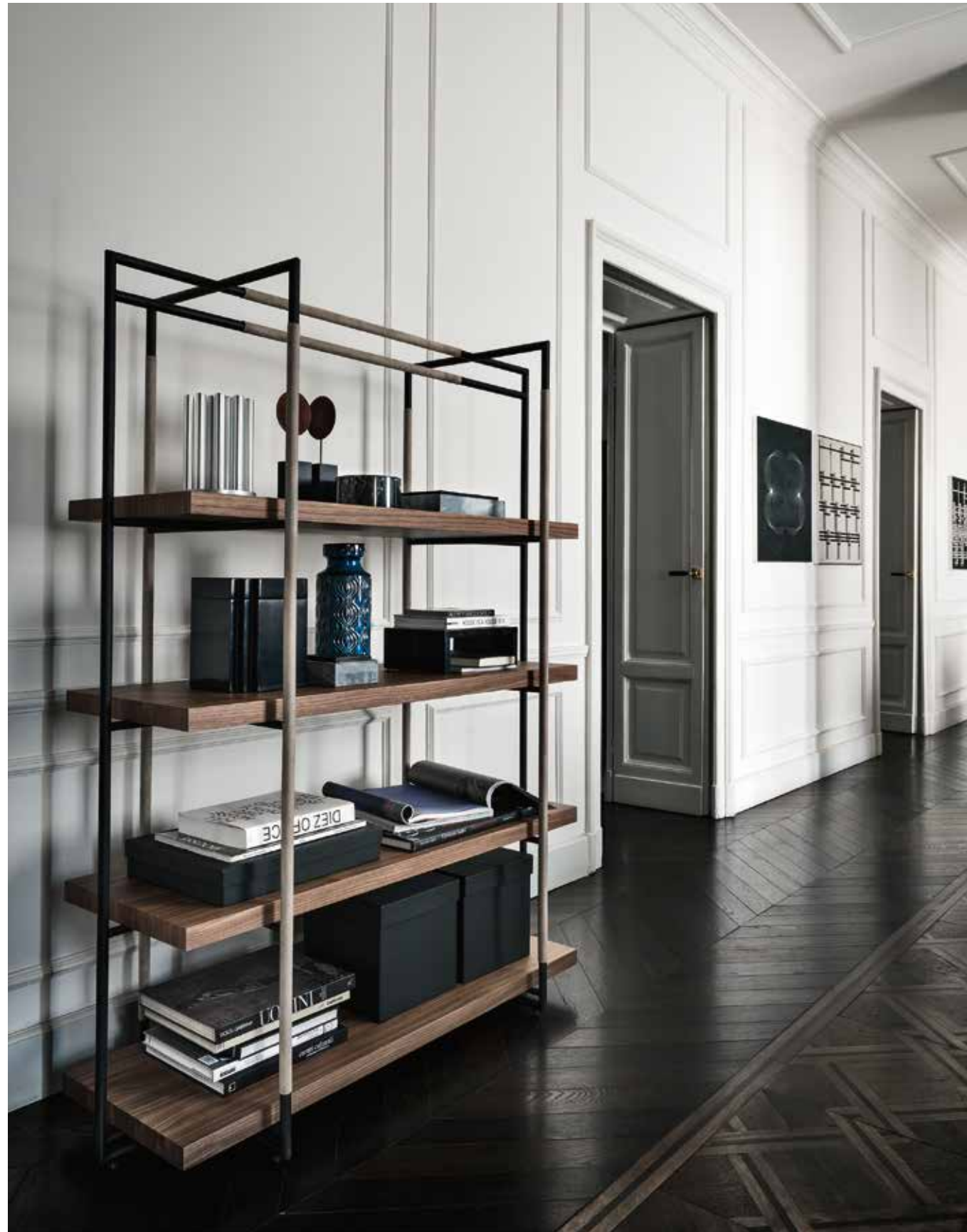

# Square

Christophe Pillet

① È una famiglia dalle linee rigorose composta da poltroncina, lounge chair, sgabello e tavolini, impreziositi dall'uso di pelle, cuoio, marmi e finiture particolari. Quattro sottili gambe in metallo fungono da struttura e da tratto distintivo di questa collezione, slanciando e regalando leggerezza a questi oggetti dal carattere minimale.

② Is a collection with clean lines composed of armchair, lounge chair, stools and accent tables, embellished by the use of leather or saddle leather, marble and special finishes. Four slim and slender metal legs form the frame and the distinctive feature of this line, imparting sharpness and airiness to these minimalistic objects.

*occasional table, stool,  
armchair, lounge chair.*



# Square Armchair

→ Bak Table / FG 442.00  
→ Square (bi-material) / FG 465.00



→ Square C (bi-material) / FG 465.02

# Square Armchair



→ Square L (mono-material) / FG 465.21  
→ Square (mono-material) / FG 465.20



# Square Armchair

→ Square L (bi-material) / FG 465.01  
→ Square 42 / FG 465.53



# Square Coffee Table



→ Square 52/42 / FG 465.61  
→ Square 34/24 / FG 465.60

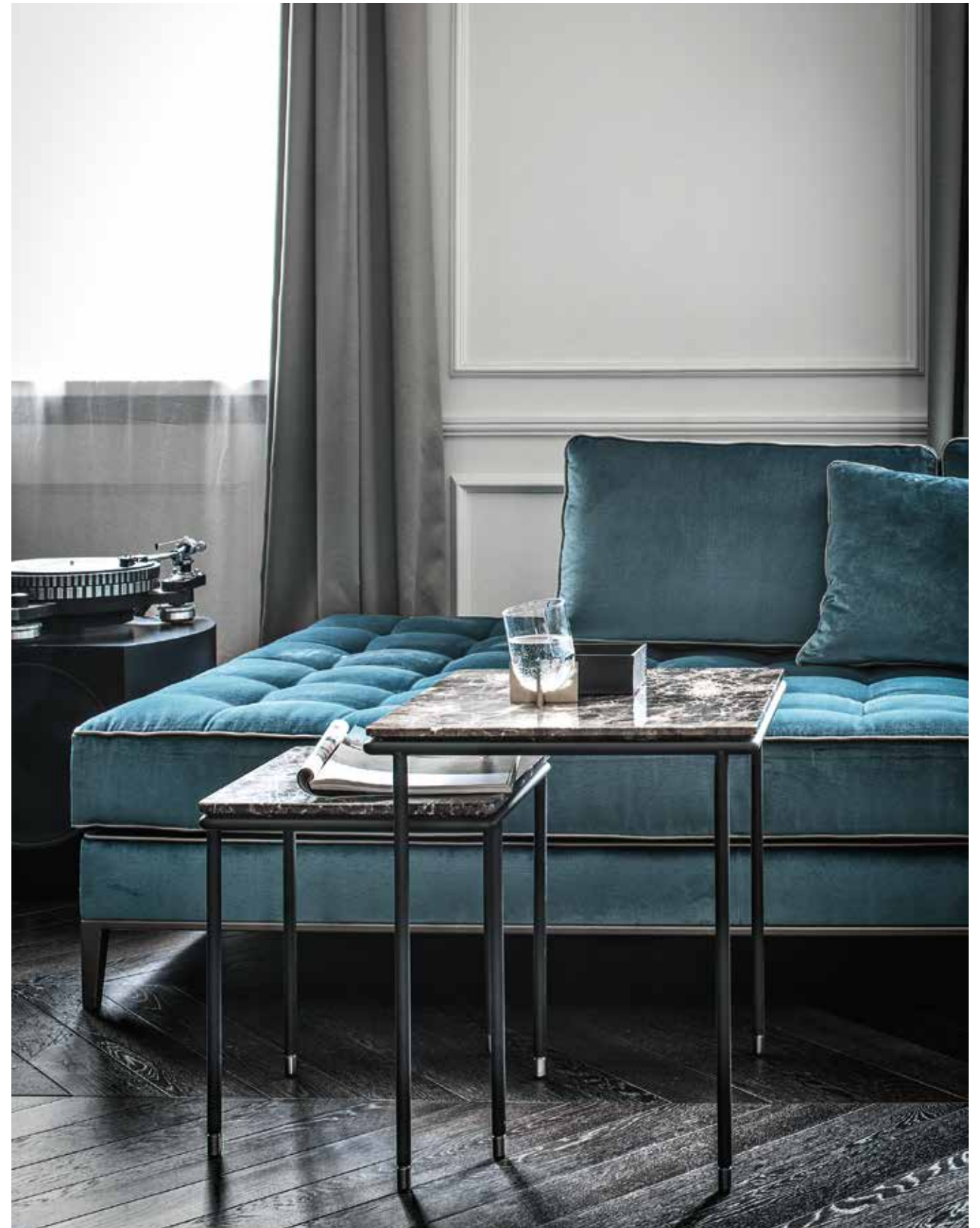

→ Square 52/42 / FG 465.61

Square Table



# Bridge

Mist—o

① È un tavolo dalla forte impronta architettonica. Travi orizzontali e verticali si incontrano a formare lo scheletro che sostiene il piano dando vita ad un oggetto razionale ed essenziale che riesce ad inserirsi perfettamente nei più svariati contesti abitativi.

② Is a table with a strong architectural character. Horizontal and vertical beams meet to form the frame that supports the top, thus creating a rational and functional object that can be perfectly introduced into the most diverse living contexts.

*table.*





→ Bridge 270 / FG 453.02  
→ Nisida / FG 342.00

Bridge



→ Bridge 240 / FG 453.00

# Hudson

Gordon Guillaumier

① Combina un design razionale e raffinato insieme ad un'esperienza di calore visivo e tattile, configurandosi come un arredo aristocratico rivisto in chiave contemporanea. I dettagli e la lavorazione minuziosa di questo day bed ne fanno il perfetto protagonista di un abitare quotidiano sofisticato e ragionato.

② Combines rational and refined design with visual and tactile warmth, taking the form of an aristocratic piece of furniture updated with a contemporary touch. The details and meticulous workmanship of this day bed make it the perfect protagonist in a sophisticated coherent daily environment.

*day bed.*

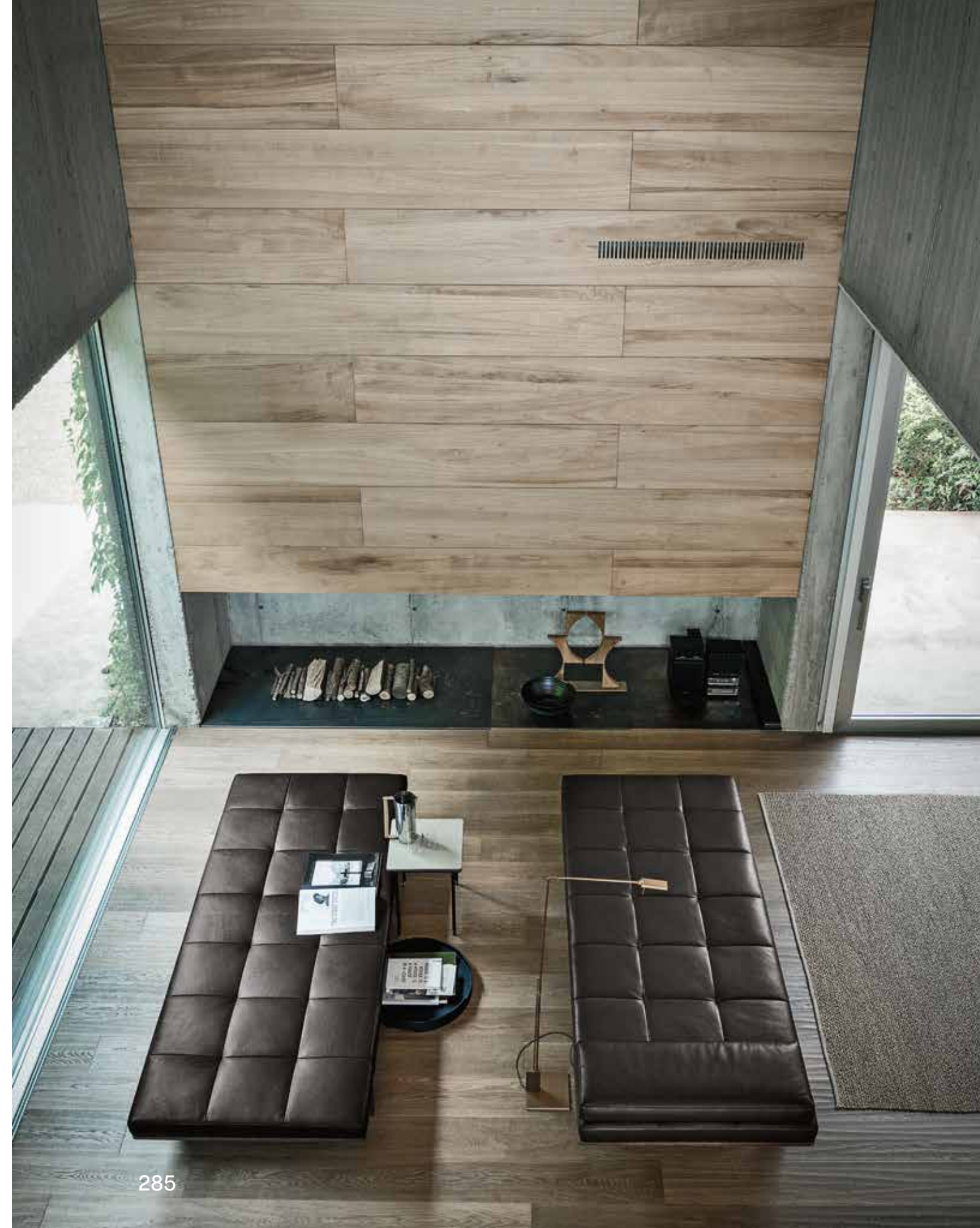



→ Hudson / FG 477.00  
→ Square 52 / FG 465.52





# Public

Dainelli Studio

① È una collezione composta da sedia, poltroncina e poltrona lounge, interamente imbottita e rivestita in pelle o tessuto. Sedia e poltroncina sono come disegnate da un'unica linea che definisce gambe, seduta, schienale e i braccioli arrotondati che, nella sedia, si trasformano nella linea retta che va a chiudere lo schienale. La lounge mantiene le forme e gli stilemi della collezione, abbassati e ampliati per dare maggiore comfort. Il divanetto, partendo dalle dimensioni e dalle proporzioni della lounge, chiude e completa la famiglia.

② Is a collection consisting of chair, armchair and lounge chair, entirely padded and upholstered in leather or fabric. Chair and armchair seem to be designed by a single line that defines legs, seat, backrest and rounded armrests that, in the chair, are transformed into the straight line that closes the backrest. The lounge maintains the shapes and styles of the collection, lowered and extended for greater comfort. The sofa, following the dimensions and proportions of the lounge, completes the family.

*chair, armchair,  
lounge chair.*



→ Artù 160 / FG 494.00  
→ Public / FG 506.00  
→ Bak Bookcase / FG 440.10



Public



→ Public L / FG 506.02



→ Public / FG 506.00  
→ Public P / FG 506.01



# Nisida

Calvi-Brambilla

① Sofisticata nella sua semplicità, conquista con la sua duplice valenza "classica" e "moderna". Disponibile in differenti varianti, Nisida è costituita da una struttura in alluminio completamente rivestita in cuoio, dove la speciale lavorazione da vita ad una seduta incredibilmente contemporanea.

② Sophisticated in its simplicity, it captures with its twofold "classic" and "modern" aspect. Available in several versions, Nisida is made up of an aluminium frame fully upholstered in saddle leather, where special workmanship creates an incredibly contemporary chair.

*chair, armchair.*





→ Nisida P / FG 342.01  
→ Nisida / FG 342.00



# Hollow

Christophe Pillet

① Orme monolitiche si contrappongono ad un comfort estremo, disegnando una lounge chair dalla personalità forte e dall'eleganza indiscutibile. Perfetta all'interno una situazione più formale Hollow riesce ad inserirsi con garbo anche all'interno di importanti ambienti domestici.

② Monolithic shapes contrast with extreme comfort, in the design of this lounge chair with great personality and undeniable elegance. Perfect in a more formal setting, Hollow also fits nicely into larger rooms in the home.

*lounge chair.*

300



→ Hollow / FG 482.00

301

Hollow



→ Hollow / FG 482.01





# Latina

G+R Fauciglietti

- ① Rappresenta la classica e intramontabile seduta in cuoio, dove il materiale riveste lo scheletro in acciaio armonico calzandolo come un abito e seguendo ogni singola linea e curvatura delle forme.
- ② Represents the classic, timeless saddle leather chair, where the material dresses the spring steel structure like a glove, following its every contour and curve.

*chair,  
armchair, stool.*





→ Latina / FG 260.00  
→ Latina P / FG 262.01



→ Latina H / FG 261.00  
→ Latina / FG 260.00



→ Latina CP / FG 265.04  
→ Latina GP / FG 265.00

# Heta

Philippe Bestenheider

① È composta da quattro aste in faggio a forma di H che sostengono il rivestimento sartoriale in cuoio, come se fosse in equilibrio su esili trampoli. Originale rivisitazione della classica bergère, abbinata al suo poggia piedi, diventa un oggetto affascinante e sofisticato da dedicare ai personali momenti di relax e tranquillità.

② Consists of four beech wood beams arranged in an H-shape, which support the tailored saddle leather upholstery, as if balanced on stilts. Original update to the classic bergère, coordinated with its footrest, it becomes a fascinating and sophisticated object to be dedicated to personal moments of relaxation and peacefulness.

*lounge chair, pouf.*



Heta



→ Heta / FG 426.00



→ Heta Pouf / FG 426.01

# Comb

Gordon Guillaumier

- ① Racchiude una grande originalità espressiva insieme a una forte tensione verso la componente strutturale, riprendendo le finiture e gli stilemi decorativi degli anni '50 e '60 in una famiglia di tavolini preziosa e disegnata.
- ② Represents great expressive originality along with a great attention to the structural component, recycling finishes and stylistic elements from the 1950s and 60s into a range of preciousy designed accent tables.

*occasional table.*





→ Comb 100 / FG 487.01  
→ Maio / FG 421.00

Comb

→ Comb 100 / FG 487.01



→ Comb 40 / FG 487.02





# Doni

Giofra

① Bar e lounge dining table dalle linee essenziali, contrappone al peso specifico ed estetico del top in marmo la leggerezza sottile del metallo che definisce la base, dando vita ad un arredo elegante, ideale, con le sue proporzioni e con il suo profilo, a completare sofisticate e intime zone lounge.

② Bar and lounge dining table with basic lines in which the lightness of metal base contrasts with the specific weight and aesthetics of the marble top, thus creating an elegant piece of furniture, ideal, with its proportions and profile, for complementing sophisticated and intimate lounge areas.

*table, lounge table,  
bar table.*



→ Doni 62 / FG 485.01  
→ Doni 73 / FG 485.00



Doni



→ Doni 100 / FG 485.02



→ Doni 100 / FG 485.02  
→ Elf B / FG 497.11

# Maio

Giopato & Coombes

① Indaga le potenzialità della pelle attraverso il suo rivestimento esclusivo e caratterizzante. Il disegno semplice e rettangolare di questo pouf viene interrotto da cuciture che ne seguono i profili e da una coppia di maniglie, decorazione e accessorio, in bilico tra funzionalità ed estetica.

② Explores the potential of leather through its exclusive and distinguishing upholstery. The simple and rectangular design of this pouf is interrupted by seams that follow its profiles and a pair of handles, decoration and accessory, that strike a balance between functionality and aesthetics.

*pouf.*

326



327

→ Maio / FG 421.00

# Sahrai

Christophe Pillet

① Lounge chair e pouf ispirati alle tradizionali poltroncine da regista. La struttura portante si distingue infatti per il tipico incrocio ad 'X' che il designer ha utilizzato come sostegno per tutta la collezione, cambiandone però il verso in orizzontale.

② Lounge chair and pouf inspired by the traditional director's chair. The bearing structure is distinguished by the typical X cross that the designer has used as supporting element for the whole collection, changing only its horizontal position.

*lounge chair, pouf.*





→ Sahrai / FG 471.00



→ Sahrai / FG 471.00  
→ Sahrai Pouf / FG 471.02

# Lyo

Gordon Guillaumier

- ① Sintetizza minimalismo e ricchezza dei materiali: le gambe in metallo cromato, unite tramite elementi incrociati dal profilo compatto, sostengono un unico foglio portante in cuoio sagomato. Un taglio centrale caratterizza e aggiunge fascino a questa seduta dal design contemporaneo.
- ② Is a synthesis of minimalism and richness of materials: the chrome-plated metal legs, connected by compact crossed elements, support a single self-supporting sheet of moulded saddle leather. A central cut adds charm to this contemporary design chair.

*chair.*





Lyo

→ Lyo / FG 352.00





# Mea

Alessandro Dubini

① Si presenta come una collezione pensata sia per sofisticati spazi domestici che per l'ufficio e l'home working, unendo l'anima tecnica di questa poltrona con le curve arrotondate e le proporzioni femminili che caratterizzano le sue forme.

② Is a collection designed for sophisticated rooms in the home as well as for the (home) office, the technical aspect of this chair is combined with its round curves and feminine proportions that characterise its shape.

*chair, chair  
with casters.*





→ Mea HC / FG 461.05  
→ Mea C / FG 462.05



→ Mea AR / FG 462.00  
→ Mea H AR / FG 461.00

# Sofy

Busetti, Garuti, Redaelli

① Si concretizza in un accogliente guscio rivestito in morbida pelle accostato in un piacevole contrasto materico e cromatico con le gambe in legno di frassino tinto noce. La sapiente lavorazione della pelle si riconosce dai preziosi dettagli di questa seduta, come la cucitura al centro dello schienale che crea un elegante effetto decorativo.

② Is a welcoming shell upholstered in leather that is juxtaposed, in a pleasant structural and colour contrast, with walnut-tinted ash wood legs. The skilful leatherwork can be seen in the precious details in this chair, such as the stitching at the centre of the back, which gives it an elegant decorative touch.

*armchair.*





→ Sofy FG 446.00



→ Sofy FG 446.00

# Lilly

Michele di Fonzo

- ① È una famiglia di sedute imbottite dal gusto classico, interamente rivestite in cuoio o in pelle. Il suo disegno semplice si completa con un'attenzione accurata all'equilibrio delle proporzioni, alla sobrietà della linea e alla finezza dei particolari.
- ② Is a collection of classic padded chairs, fully covered in leather or saddle leather. Its simple design is complemented by the thorough attention paid to the balance of proportions, to the sober lines and refined details.

*chair, stool.*



Lilly



Lilly C / FG 408.02



→ Lilly / FG 408.00



→ Lilly H / FG 408.01

# Aria

Steve Leung

① Seduta discreta ma dal tratto rigoroso, Aria combina la praticità e funzionalità con l'eleganza assoluta di materiali come l'acciaio e il cuoio. Leggera alla vista, la sedia Aria si compone di una struttura in acciaio verniciata nero opaco che sostiene una sottile scocca rivestita interamente in cuoio. Un design in grado di restituire una forte uniformità visiva grazie alla continuità tra seduta e schienale in dialogo con le delicate linee della struttura, combinando look scolpito a fluidità. Presenza delicata e armonica, estremamente funzionale nel suo essere impilabile, è un'opzione ideale per il mondo del contract, inserendosi con garbo sia in ambienti pubblici che domestici.

② With its discreet and precise lines, Aria combines practicality and functionality with the simple elegance of materials such as steel and leather. The Aria chair has visual appeal, with a matt black painted steel frame supporting a thin shell entirely covered in leather. The design offers strong visual uniformity in which continuity between the seat and backrest dialogues with the delicate lines of the frame in a blend of fluidity and a sculpted appearance. Its delicate and harmonious presence and its stackability make it an ideal option for the contract world that adapts easily to both public and domestic environments.

*chair.*







→ Aria / FG 545.00  
→ Myon 240 / 541.10

# Dante

Michele di Fonzo

① È dominato dall'essenzialità della forma la cui particolarità consiste nel completo rivestimento in cuoio, impreziosito con discrezione dalle diverse impunture che disegnano sul piano del tavolo linee geometriche e nette.

② Is dominated by the sheer essence of its shape, which is especially due to the fact that it is completely clad in saddle leather, discretely embellished by the various stitching patterns that draw clean geometric lines on the table top.

*table, desk.*





→ Dante 180 / FG 366.02  
→ Iki PW / FG 333.06

# Dante

→ Dante 150 / FG 366.00



# Ele

Michele di Fonzo

① Lega in uno speciale connubio i lineamenti sinuosi delle sue forme con il carattere forte del cuoio che la ricopre interamente. Le impunture a vista sagomano un leggero motivo grafico sullo schienale impreziosendo la seduta con elegante discrezione.

② Binds in a special marriage the sinuous features of its shapes with the strength of saddle leather, which covers it completely. The visible stitching creates a delicate graphic motif on the backrest, embellishing the seat with elegant discretion.

*chair.*

360



361



→ Ele / FG 457.00

# Fizzy

Gordon Guillaumier

① Sfoggia, pur nella pulizia delle sue forme, dettagli preziosi e particolari sartoriali cuciti a mano, come la cucitura a punto cavallo, che rendono questo sgabello dal fusto regolabile un oggetto deciso e sofisticato.

② Even with its clean lines, it showcases valuable hand-stitched details, like the blanket stitching, which turns this height-adjustable stool into an incisive and sophisticated object.

*stool.*

364



365



→ Fizzy / FG 458.00  
→ Fizzy / FG 458.01





# Dindi

Michele di Fonzo

① Intramontabile evergreen, classica seduta completamente rivestita in cuoio, è un oggetto che si adatta ad ogni luogo dell'abitare, inserendosi con grazia negli spazi più minimali e in quelli più sontuosi. Lo schienale, realizzato in uno speciale acciaio armonico flessibile con memoria, aggiunge movimento in un equilibrio perfetto tra estetica e comodità.

② A timeless evergreen, this classic chair, fully upholstered in saddle leather, is an object that suits every setting, which can be gracefully integrated into the most minimalist of spaces as well as the most sumptuous ones. The back, in special flexible spring "memory" steel, conveys dynamism to a perfect balance between beauty and comfort.

*chair.*





Dindi

→ Dindi / FG 448.00

# Canouan

Giofra

- ① Definisce un nuovo concetto di seduta in pelle, modulando seduta e schienale con una serie di imbottiture tubolari in grado di assicurare un comfort senza pari. L'accostamento con la finitura cromata della base dona leggerezza al progetto, facendo da contrappunto alle sue forme sinuose.
- ② Defines a new concept in leather seating, modulating the seat and back with ribbed padding that ensures unrivalled comfort. The juxtaposition with the chrome finish on the base provides this item with airiness, offsetting its sinuous shapes.

*chair with casters.*





→ Canouan D / FG 282.03



# Viae

Analogia Project

① Si ispira ai ciottoli delle antiche strade romane la cui forma liscia e levigata deriva dall'uso e dal tempo. Appendiabiti – svuota tasche, Viae riesce ad unire funzionalità e vanità in un oggetto del desiderio dal carattere prezioso dedicato agli ambienti più intimi della casa.

② Is inspired by the cobblestones of ancient Roman roads, shaped and polished by time and wear. A clothes stand - valet tray, Viae successfully marries functionality and design in a desirable, luxurious item suitable for the most intimate domestic environments.

*valet stand.*

376



377

Viae



→ Viae Valet Stand / FG 484.50

# 4. Technical

*Sheet*

Aria

↳ Sedia impilabile con scocca in multistrato curvato rivestita in cuoio. Struttura in acciaio verniciata nero opaco.

↳ Stackable chair with curved plywood shell covered in leather. Matt black painted steel structure.

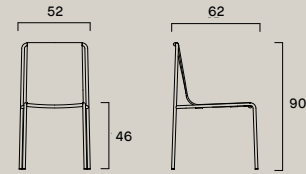

Aria  
Chair  
FG 545.00

Bella

↳ Famiglia di sedute imbottite in poliuretano espanso ignifugo e rivestite in pelle o tessuto. Struttura in acciaio, schienale flessibile con anima in acciaio armonico. Gambe rivestite in pelle, in legno di frassino o in metallo. Schienale alto o basso, con e senza braccioli. Lo sgabello è disponibile con altezza fissa o regolabile con seduta rivestita in pelle o tessuto e struttura in metallo cromo lucido o verniciato.

↳ Collection of seating padded with flame-retardant polyurethane foam and upholstered in leather or fabric. Steel frame, flexible back with spring steel core. Available upholstered with leather or fabric or with ash wood or metal legs, with high or low back, with or without armrests. The stool is also available in a height-adjustable version, with a seat upholstered in leather or fabric and a polished chrome or painted base.

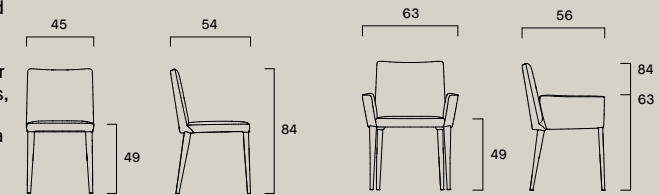

Bella  
Side chair  
FG 320.01

Bella P  
Armchair  
FG 320.03

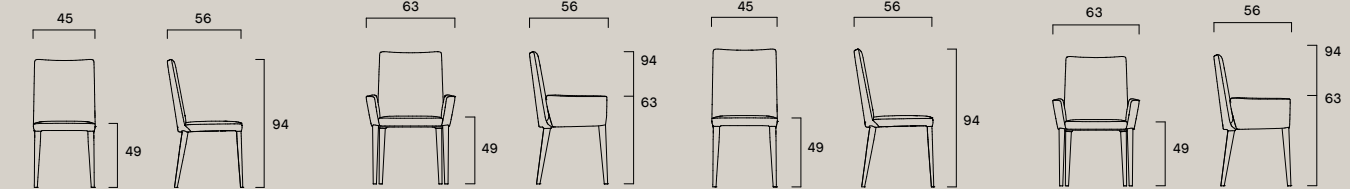

Bella H  
Side chair  
FG 320.00

Bella HP  
Armchair  
FG 320.02

Bella H GM metal legs  
Side chair  
FG 320.06

Bella HP GM metal legs  
Armchair  
FG 320.08

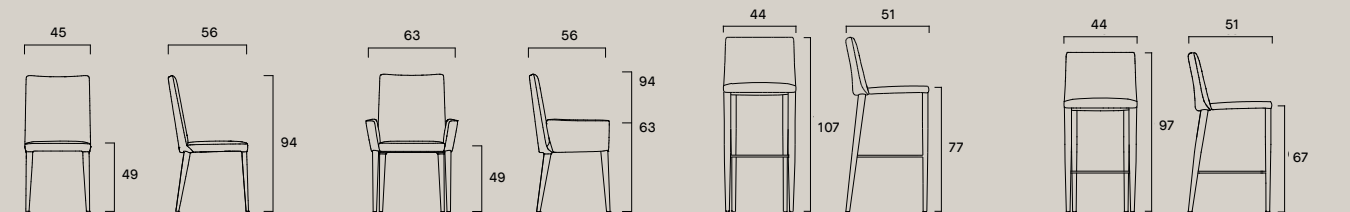

Bella HW wooden legs  
Side chair  
FG 320.10

Bella HPW wooden legs  
Armchair  
FG 320.12

Bella B  
Stool  
FG 320.16

Bella C  
Stool  
FG 320.15

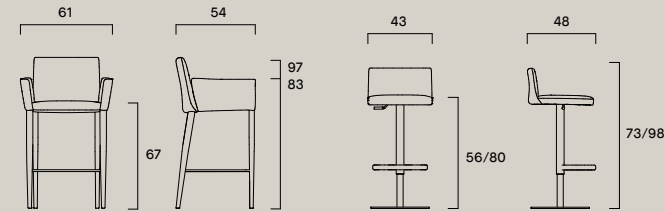

Bella CP  
Stool  
FG 320.14

Bella GP  
Height-adjustable stool  
FG 320.04

Blyn

↳ Famiglia di sedute leggermente imbottite e interamente rivestite in cuoio. Struttura in acciaio, disponibile con e senza braccioli.

↳ Collection of lightly padded chairs upholstered in saddle leather. Steel frame, available with and without armrests.

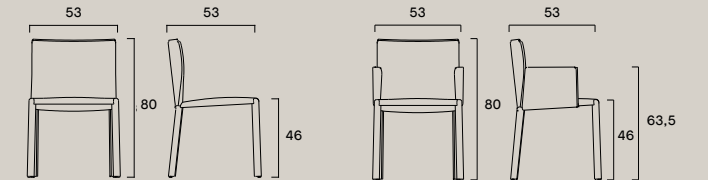

Blyn  
Side chair  
FG 533.00

Blyn P  
Armchair  
FG 533.01

Canouan

↳ Seduta con scocca in multistrato imbottito in poliuretano espanso ignifugo e rivestita in pelle. Gambe in acciaio cromato lucido con ruote.

↳ Chair with multilayer shell padded with flame-retardant foam and upholstered in leather. Steel polished chrome swivel base, with casters.

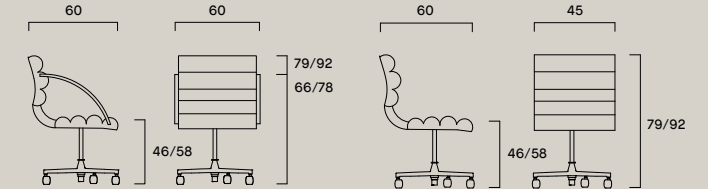

Canouan D  
Office armchair  
FG 282.03

Canouan 5  
Office armchair  
FG 282.05

Clubby

↳ Famiglia di sedute completamente imbottite con basamento in metallo finitura ottone spazzolato. Poltrona lounge con basamento girevole, rivestita in pelle o tessuto, con guscio esterno rivestito in pelle, cuoio o tessuto. Pouf rivestito in pelle o tessuto.

↳ Collection of fully padded chairs with base finished in brushed brass. Lounge chair with swivel base, upholstered in leather or fabric, with an external shell upholstered in leather, saddle leather or fabric. Pouf upholstered in leather or fabric.

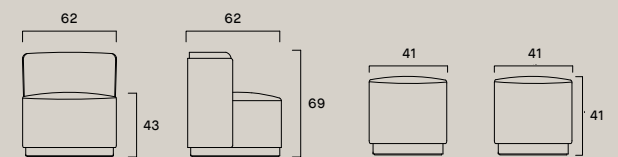

Clubby  
Swivel lounge armchair  
FG 493.00, FG 493.20, FG 493.30

Clubby Pouf  
Pouf  
FG 493.10

Cocoon

↳ Poltrona lounge e pouf imbottiti e rivestiti in pelle o tessuto, piedini in massello di noce. Lounge con scocca in alluminio rivestita in cuoio.

↳ Lounge chair and pouf, padded and upholstered in leather or fabric, solid walnut feet. Back of chair with aluminium-core frame upholstered in saddle leather.

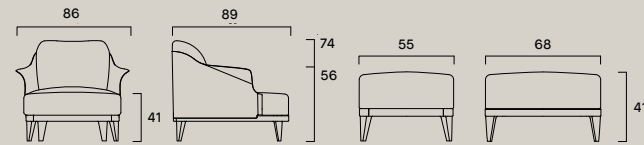

Cocoon  
Lounge armchair  
FG 495.00

Cocoon Pouf  
Pouf  
FG 495.01

Dindi

↳ Sedia imbottita in poliuretano espanso ignifugo e rivestita in cuoio. Struttura in acciaio, schienale flessibile con anima in acciaio armonico.

↳ Chair padded with flame-retardant polyurethane foam and upholstered in saddle leather. Steel frame, flexible back with spring steel core.

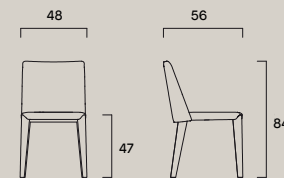

Dindi  
Side chair  
FG 448.00

Doa

↳ Seduta con scocca in multistrato imbottita in poliuretano espanso ignifugo e rivestita in pelle. Gambe e struttura in legno massello di frassino. Disponibile con o senza braccioli.

↳ Chair with plywood shell padded with flame-retardant polyurethane foam and upholstered in leather. Legs and frame in solid ash wood. Available with or without armrests.

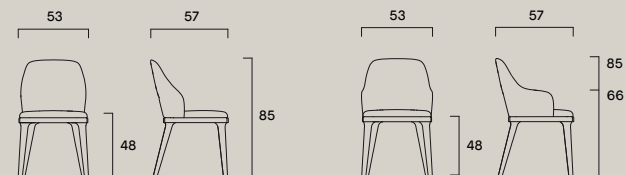

Doa  
Side chair  
FG 464.03

Doa P  
Armchair  
FG 464.02

Ele

↳ Sedia con scocca in multistrato leggermente imbottita e rivestita in cuoio. Gambe in acciaio rivestite in cuoio.

↳ Chair with lightly padded plywood shell and steel legs, fully upholstered in saddle leather.

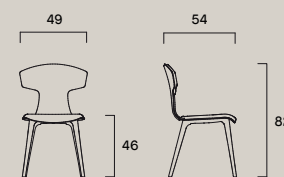

Ele  
Side chair  
FG 457.00

Elf

↳ Famiglia di sedute imbottite in poliuretano espanso, interamente rivestite in pelle o tessuto. Struttura in acciaio con schienale flessibile. Disponibile con schienale alto o basso, con e senza braccioli.

↳ Collection of chairs padded with polyurethane foam and fully upholstered in leather or fabric. Steel frame with flexible back. Available with high or low back, with or without armrests.

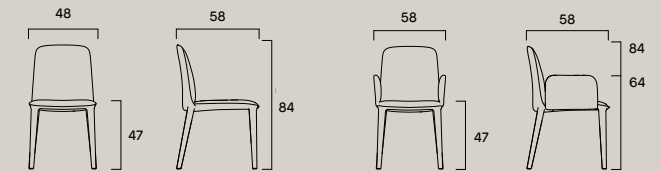

Elf  
Side chair  
FG 497.00

Elf P  
Armchair  
FG 497.01

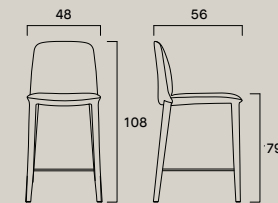

Elf B  
Bar stool  
FG 497.11

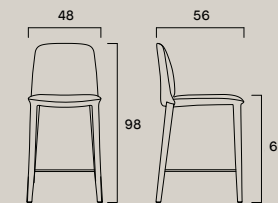

Elf C  
Counter stool  
FG 497.10

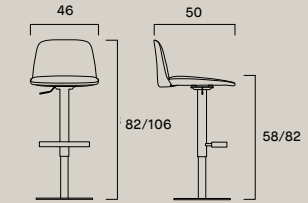

Elf GP  
Height-adjustable stool  
FG 497.12

Fizzy

↳ Sgabello regolabile con seduta imbottita e rivestita in pelle o tessuto. Struttura in metallo cromo lucido. Schienale in metallo cromo lucido a o in pelle cucito a mano.

↳ Height-adjustable stool with padded seat upholstered in leather or fabric. Polished chrome base. Metal backrest available chrome plated, or with hand-stitched leather insert.

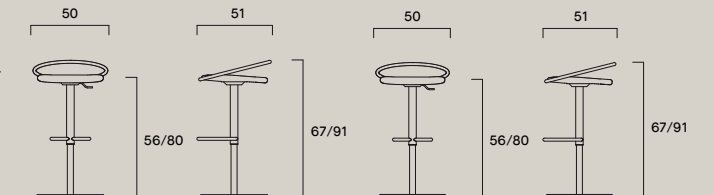

Fizzy Metal Backrest  
Height-adjustable stool  
FG 458.00

Fizzy Leather Backrest  
Height-adjustable stool  
FG 458.01

Heta

↳ Poltrona con struttura in faggio. Seduta, schienale e braccioli autoportanti in cuoio pieno fiore. Cuscini di seduta, poggiatesta e poggiaresi in gommapiuma e ovatta rivestiti in pelle. Pouf con struttura in faggio e seduta autoportante in cuoio pieno fiore con cuscino in piuma d'oca rivestito in pelle.

↳ Armchair with beech wood frame. Self supporting full grain leather seat, back and armrests. Seat, headrest and lumbar support cushions in foam and wadding, upholstered in leather. Pouf with beech wood frame and self-supporting seat in full grain leather with goose down cushion, upholstered in leather.

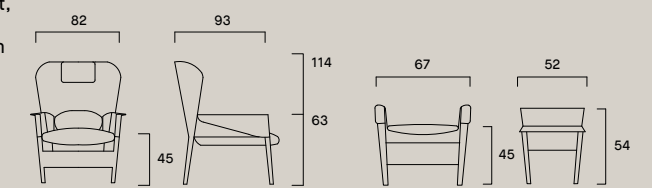

Heta Bergere  
Lounge armchair  
FG 426.00

Heta Pouf  
Pouf  
FG 426.01



Hollow

↳ Poltrona lounge interamente imbottita e rivestita in pelle o tessuto. Struttura in metallo rivestita in poliuretano espanso ignifugo. Disponibile anche base con ritorno girevole.

↳ Fully padded lounge chair, upholstered in leather or fabric. Metal frame and flame-retardant polyurethane foam. Swivel base also available with automatic return.

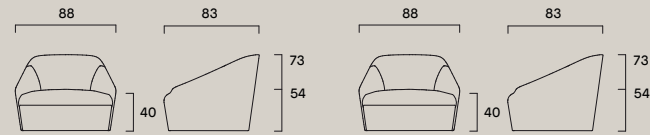

Hollow  
Lounge armchair  
FG 482.00

Hollow  
Swivel lounge armchair  
FG 482.01

Iki

↳ Famiglia di sedute con sedile e schienale leggermente imbottiti e rivestiti in cuoio, pelle o tessuto. Telaio in metallo verniciato nero, gambe in frassino. Disponibile con e senza braccioli.

↳ Collection of chairs with lightly padded seat and back, upholstered in leather, saddle leather or fabric. Black metal frame, ash wood legs. Available with or without armrests.

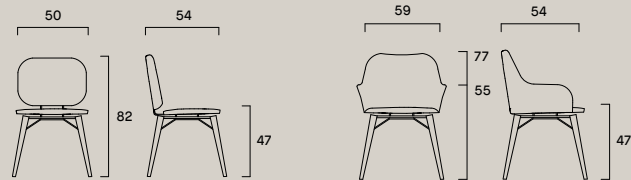

Iki W  
Side chair  
FG 333.05

Iki PW  
Armchair  
FG 333.06

Latina

↳ Famiglia di sedute leggermente imbottite e interamente rivestite in cuoio. Struttura in acciaio, schienale flessibile con anima in acciaio armonico. Disponibile con schienale alto o basso, con e senza braccioli. Lo sgabello è disponibile con altezza fissa o regolabile con seduta imbottita e rivestita in cuoio e struttura in metallo cromo lucido, satinato o nero.

↳ Collection of lightly padded chairs and stools, fully upholstered in saddle leather. Steel frame, flexible back with spring steel core. Available with high or low back, with or without armrests. Height-adjustable stool with padded seat, upholstered in saddle leather on a polished chrome, matt chrome or black painted base.

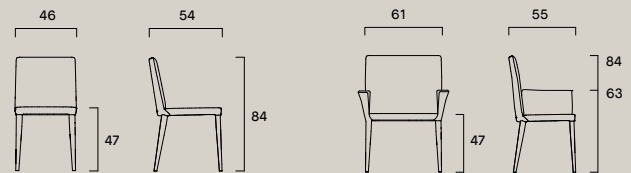

Latina  
Side chair  
FG 260.00

Latina P  
Armchair  
FG 262.01

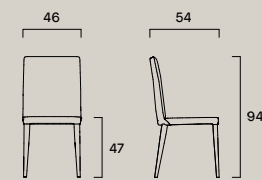

Latina H  
Side chair  
FG 261.00

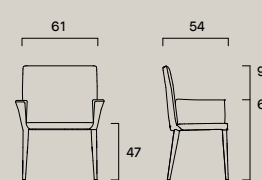

Latina HP  
Armchair  
FG 262.00

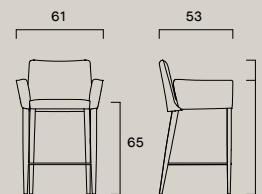

Latina CP  
Stool  
FG 265.04

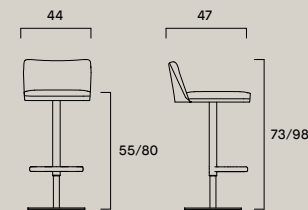

Latina GP  
Height-adjustable stool  
FG 265.00

Lilly

↳ Famiglia di sedute leggermente imbottite e rivestite interamente in cuoio o pelle. Struttura in acciaio. Disponibile con schienale alto o basso.

↳ Collection of lightly padded chairs, fully upholstered in leather or saddle leather. Steel frame. Available with high or low back.

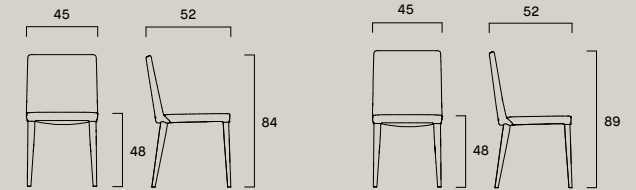

Lilly  
Side chair  
FG 408.00

Lilly H  
Side chair  
FG 408.01

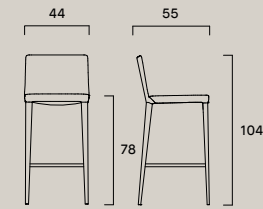

Lilly B  
Bar stool  
FG 408.03

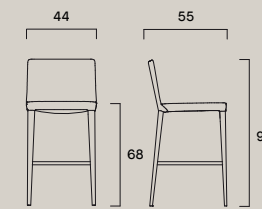

Lilly C  
Counter stool  
FG 408.02

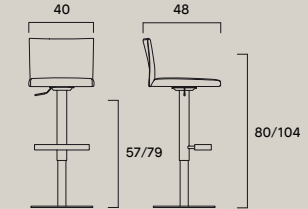

Lilly GP  
Height-adjustable stool  
FG 408.04

Lyo

↳ Sedia con struttura tubolare in metallo cromo lucido, schienale e seduta in cuoio doppiato autoportante.

↳ Chair with polished chrome tubular steel structure, back and seat in self-supporting doubled saddle leather.

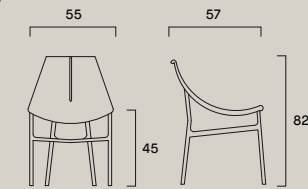

Lyo  
Side chair  
FG 352.00

Maio

↳ Pouf imbottito in poliuretano espanso ignifugo e rivestito in pelle cucita al vivo.

↳ Pouf padded with flame-retardant polyurethane foam and upholstered in leather with raw cut edges.

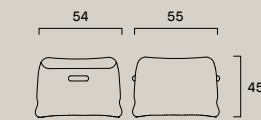

Maio  
Pouf  
FG 421.00

Mea

↳ Famiglia di poltrone rivestite in pelle o tessuto con scocca in poliuretano schiumato a freddo. Disponibile con schienale alto o basso. Base girevole in alluminio lucido disponibile a 4 razze o a 5 razze con ruote. Modello con 5 razze e ruote disponibile con meccanismo a gas per la regolazione dell'altezza e meccanismo basculante.

↳ Collection of armchairs upholstered in leather or fabric with cold-moulded polyurethane shell. Available with high or low back. Swivel base in polished aluminium available with 4 or 5 rays with casters. Model with 5 star base and casters available with gas lift mechanism for height adjustment and tilt adjustment.

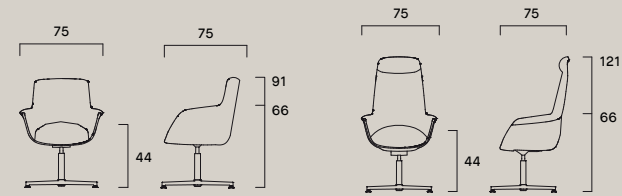

Mea C  
Armchair  
FG 462.05

Mea HC  
Armchair  
FG 461.05

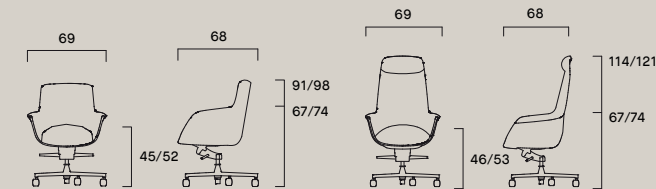

Mea AR  
Armchair with casters  
FG 462.00

Mea H AR  
Armchair with casters  
FG 461.00

Nisida

↳ Famiglia di sedute con struttura in alluminio leggermente imbottite e interamente rivestite in cuoio. Disponibile con e senza braccioli.

↳ Collection of chairs with aluminium frame, lightly padded and fully upholstered in saddle leather. Available with or without armrests.

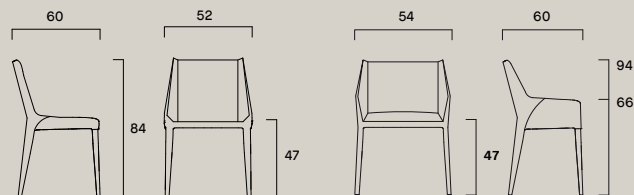

Nisida  
Side chair  
FG 342.00

Nisida P  
Armchair  
FG 342.01

Ocean

↳ Poltrona lounge con struttura in multistrato imbottita, rivestita in pelle o tessuto. Basamento girevole in acciaio con ritorno verniciato bronzo scuro o con verniciatura colore RAL su richiesta. Pouf con struttura in multistrato imbottita rivestita in pelle o tessuto. Basamento fisso in acciaio verniciato bronzo scuro o con verniciatura colore RAL su richiesta.

↳ Lounge armchair with padded plywood structure upholstered in leather or fabric. Steel swivel base with return mechanism with dark bronze finish or custom painted in any RAL color upon request. Pouf with padded plywood structure upholstered in leather or fabric. Fixed steel base with dark bronze finish or custom painted in any RAL color upon request.

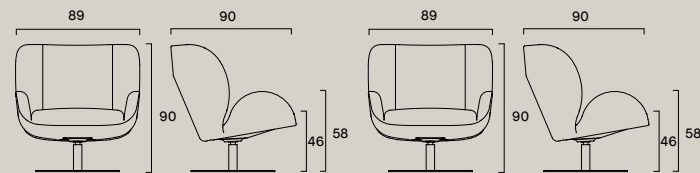

Ocean (mono-material)  
Swivel lounge armchair  
FG 527.00

Ocean (bi-material)  
Swivel lounge armchair  
FG 527.20

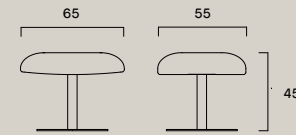

Ocean Pouf  
FG 527.50

Olimpia

↳ Famiglia di sedute con struttura in tubolare d'acciaio verniciato o cromato e scocca imbottita e rivestita in pelle o tessuto. Disponibile con e senza braccioli. Schienale con dettaglio bottoni metallici.

↳ Collection of chairs with a tubular frame in painted steel or chrome and padded body upholstered in leather or fabric. Available with or without armrests. Back with metal button details.

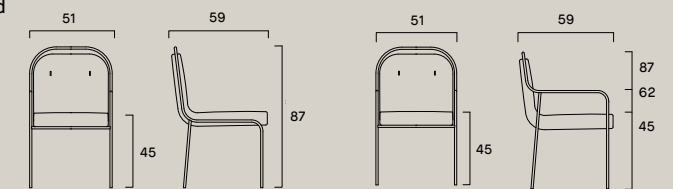

Olimpia  
Side chair  
FG 501.00

Olimpia P  
Armchair  
FG 501.01

Ponza

↳ Seduta imbottita in poliuretano espanso ignifugo e rivestita in pelle o tessuto. Gambe in legno di frassino verniciate a poro aperto. Sgabello disponibile con altezza regolabile con seduta imbottita e rivestita in pelle o tessuto e struttura in metallo cromo lucido o verniciato nero.

↳ Chair padded with flame-retardant polyurethane foam and upholstered in leather or fabric. Legs in open-pore lacquered ash wood. Height-adjustable stool with padded seat, upholstered in leather or fabric on a polished chrome plated or black painted.

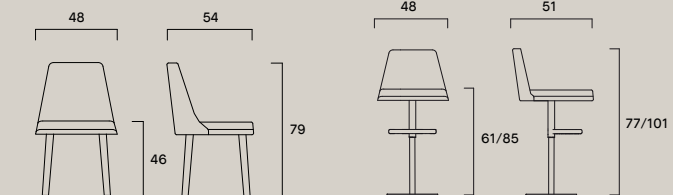

Ponza  
Side chair  
FG 405.00

Ponza GP  
Height-adjustable stool  
FG 405.07

Public

↳ Famiglia di sedute interamente imbottite in poliuretano espanso ignifugo e rivestite in pelle o tessuto. Struttura in legno. Puntali disponibili in acciaio verniciato.

↳ Collection of chairs fully padded with flame-retardant polyurethane foam and upholstered in leather or fabric. Wooden frame. End caps available in painted steel.

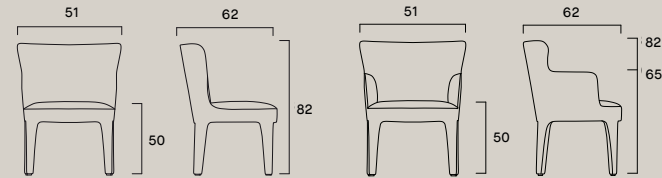

Public  
Side chair  
FG 506.00

Public P  
Armchair  
FG 506.01

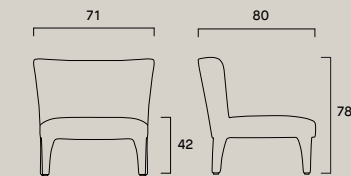

Public L  
Lounge armchair  
FG 506.02

Quattro

↳ Pouf con base in tubo d'acciaio curvato verniciato nero opaco e seduta imbottita in poliuretano a densità differenziata rivestito in pelli o tessuti di collezione.

↳ Pouf with matt black painted curved steel tube frame and seat in polyurethane foam of different densities, covered in leather or fabric from our collection.

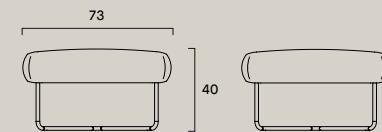

Quattro Pouf  
FG 518.00

Riviera

↳ Poltrona lounge con struttura in tubolare d'acciaio verniciato o cromato, seduta e schienale in cuoio. Cuscini sfoderabili, imbottiti, rivestiti in pelle o tessuto.

↳ Lounge armchair with tubular frame in chrome plated or painted steel, seat and back in saddle leather. Removable cushions, padded and upholstered in leather or fabric.

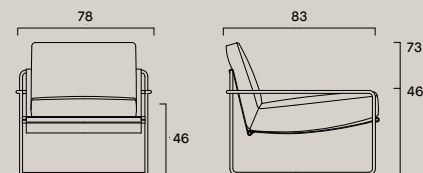

Riviera  
Lounge armchair  
FG 499.00

Sahrai

↳ Poltrona lounge con seduta e schienale imbottiti in poliuretano espanso ignifugo e rivestiti in pelle o tessuto. Struttura e braccioli in acciaio verniciato con dettagli in pelle o tessuto. Pouf con seduta imbottita e rivestita in pelle o tessuto.

↳ Lounge armchair with padded flame-retardant polyurethane foam seat and back, upholstered in leather or fabric. Lacquered steel frame and armrests with leather or fabric details. Pouf with padded seat upholstered in leather or fabric.

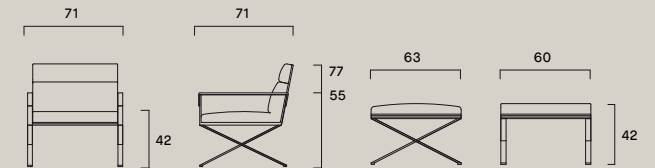

Sahrai  
Lounge armchair  
FG 471.00

Sahrai Pouf  
FG 471.01

Syren

↳ Poltrona lounge con struttura in acciaio verniciato nero opaco e scocca esterna in cuoio. Sedile in multistrato imbottito in poliuretano espanso a quote differenziate e cinghiato rivestito in pelle o tessuto. Schienale e braccioli in poliuretano espanso e fiocco di poliuretano, rivestiti in pelle o tessuto.

↳ Lounge armchair with matt black painted steel structure and shell in saddle leather. Seat in plywood belted and padded in polyurethane foam of different densities, covered in leather or fabric. Backrest and armrests padded in polyurethane foam and straple, covered in leather or fabric.

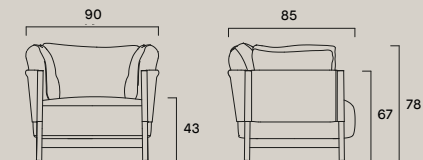

Syren  
Lounge Armchair  
FG 542.00

Siloe

↳ Famiglia di sedute con struttura in acciaio o legno di frassino, seduta e schienale in multistrato, imbottiti e rivestiti in pelle o tessuto. Disponibile con e senza braccioli. Lo sgabello è disponibile solo con struttura in legno di frassino e in due altezze.

↳ Collection of chairs with steel or ash wood frame, padded plywood seat and back, upholstered in leather or fabric. Available with and without armrests. The stool is available with ash wood frame only and in two heights.

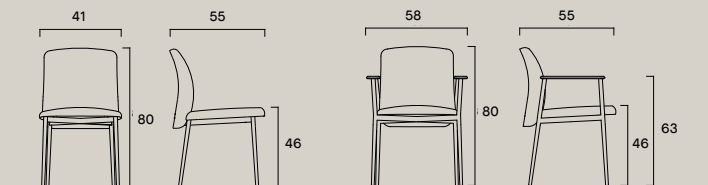

Siloe  
Side chair  
FG 534.00

Siloe P  
Armchair  
FG 534.01

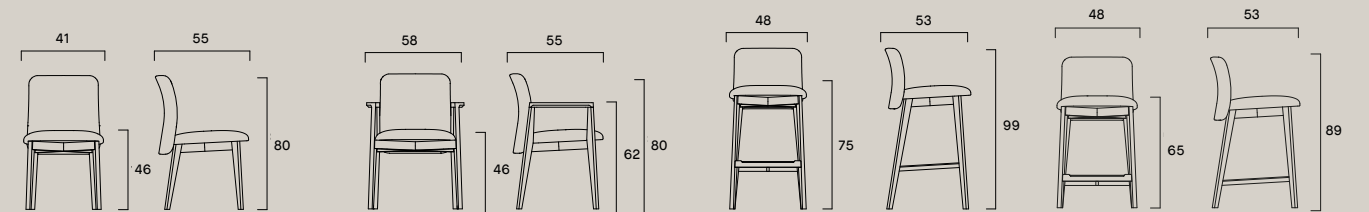

Siloe W  
Side chair  
FG 534.10

Siloe PW  
Armchair  
FG 534.11

Siloe B  
Stool  
FG 534.13

Siloe C  
Stool  
FG 534.12

Sofy

↳ Poltroncina con scocca in multistrato imbottita in poliuretano espanso ignifugo e rivestita in pelle o tessuto. Gambe in frassino.

↳ Armchair with plywood shell padded with flame-retardant polyurethane foam and upholstered in leather or fabric. Ash wood legs.

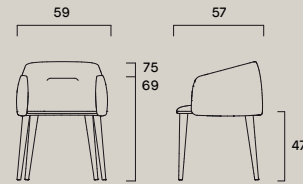

Sofy  
Armchair  
FG 446.00

Winnie

↳ Poltrona lounge con struttura in metallo leggermente imbottita e rivestita in pelle o tessuto. Cuscini di seduta e schienale imbottiti in piuma ecologica e rivestiti in pelle o tessuto. Piedini in ottone brunito o verniciati neri.

↳ Lounge armchair with lightly padded metal frame upholstered in leather or fabric. Seat and back cushions filled with organic down and upholstered in leather or fabric. Burnished brass or black painted feet.

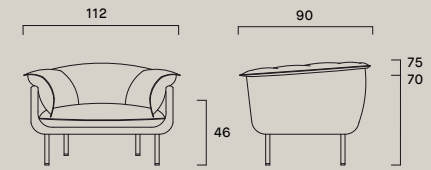

Winnie  
Lounge armchair  
FG 483.00

Square

↳ Famiglia di sedute con scocca leggermente imbottita e rivestita in cuoio, in pelle o tessuto. Cuscini in poliuretano sagomato rivestiti in pelle o tessuto. Gambe in tubo di acciaio verniciato, puntali in alluminio spazzolato.

↳ Collection of armchairs and stools with lightly padded shell, upholstered in leather, saddle leather or fabric. Moulded polyurethane seat cushions, upholstered in leather or fabric. Painted tubular steel legs with brushed aluminium tips.

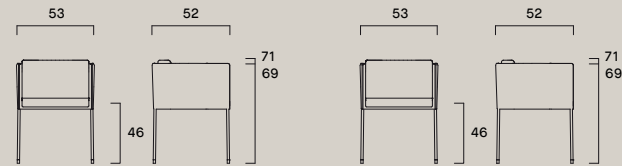

Square (mono-material)  
Armchair  
FG 465.20

Square (bi-material)  
Armchair  
FG 465.00

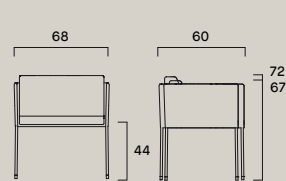

Square L (mono-material)  
Lounge armchair  
FG 465.21

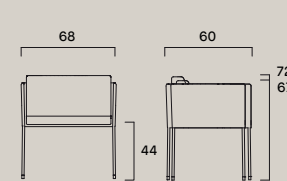

Square L (bi-material)  
Lounge armchair  
FG 465.01

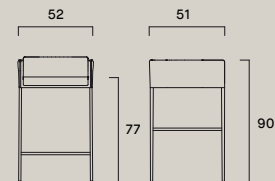

Square B (mono-material)  
Bar stool  
FG 465.23

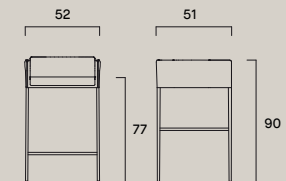

Square B (bi-material)  
Bar stool  
FG 465.03

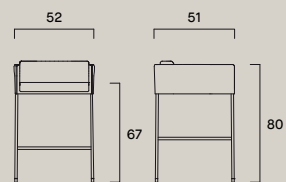

Square C (mono-material)  
Counter stool  
FG 465.22

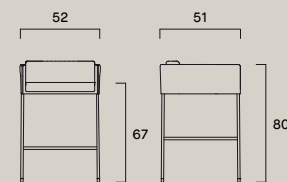

Square C (bi-material)  
Counter stool  
FG 465.02

Caruso

↳ Chaise-longue con scocca in multistrato rivestita in cuoio e materassino imbottito rivestito in pelle o tessuto. Cuscino poggia testa removibile rivestito in pelle o tessuto. Struttura in acciaio verniciato nero opaco.

↳ Chaise-longue with plywood shell covered in saddle leather and padded mattress upholstered in leather or fabric. Removable headrest cushion upholstered in leather or fabric. Matt black painted steel structure.

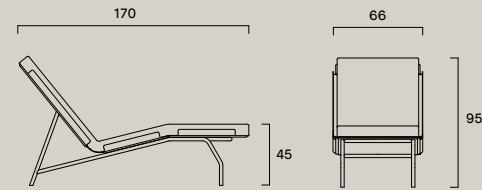

Caruso  
Chaise-longue  
FG 539.00

Gast

↳ Collezione di divani con struttura in legno multistrato imbottita in poliuretano espanso a quote differenziate. Cuscini di seduta e schienale in poliuretano espanso e memory foam con rivestimento in trapuntino. Rivestimento in pelle o tessuto. Piedini in materiale termoplastico nero a scomparsa.

↳ Collection of sofas with a plywood structure padded with polyurethane foam of different densities. Seat and back cushions in polyurethane and memory foam with quilt cover. Upholstered in leather or fabric. Hidden glides in black thermoplastic material.

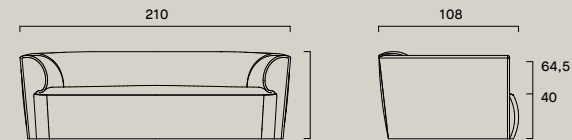

Gast 210  
Sofa  
FG 521.00

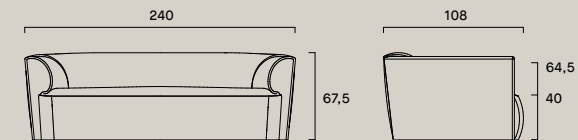

Gast 240  
Sofa  
FG 521.01

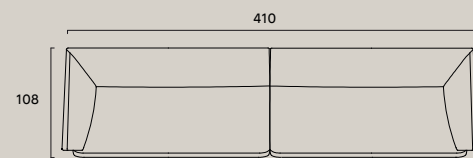

Gast  
Composition 1  
FG 521.10 + FG 521.11

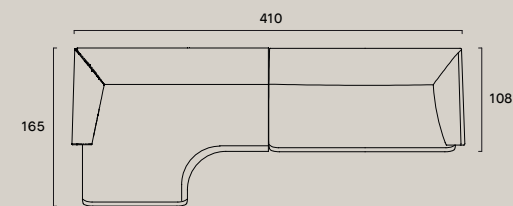

Gast  
Composition 2  
FG 521.12 + FG 521.11

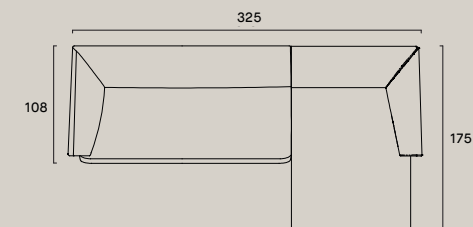

Gast  
Composition 3  
FG 521.10 + FG 521.21

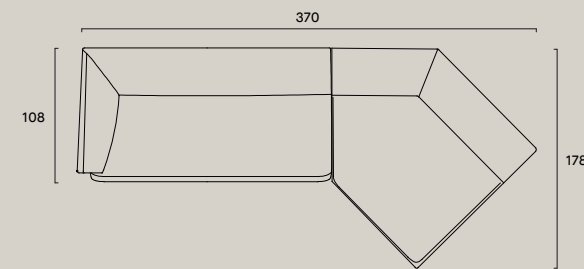

Gast  
Composition 4  
FG 521.10 + FG 521.14

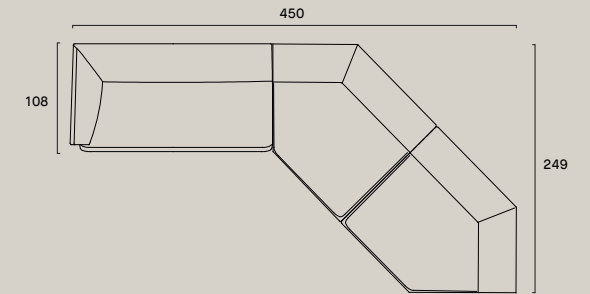

Gast  
Composition 5  
FG 521.10 + FG 521.14 + FG 521.15

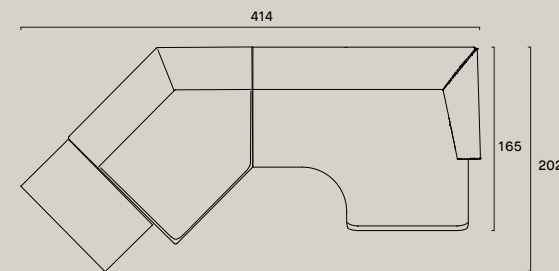

Gast  
Composition 6  
FG 521.30 + FG 521.15 + FG 521.13

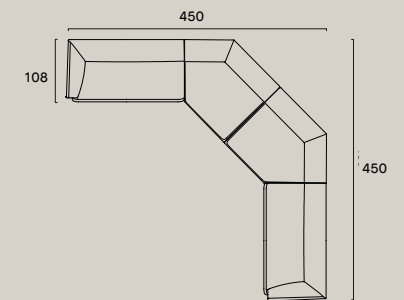

Gast  
Composition 7  
FG 521.10 + FG 521.14 + FG 521.15 + FG 521.30 + FG 521.11

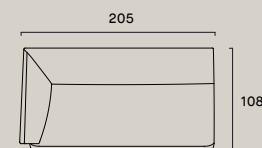

Gast (left end section)  
Sofa  
FG 521.10

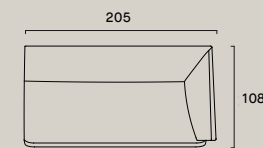

Gast (right end section)  
Sofa  
FG 521.11

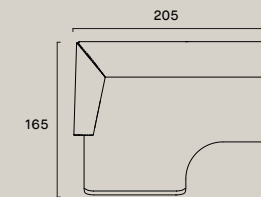

Gast (rounded left end section)  
Sofa  
FG 521.12

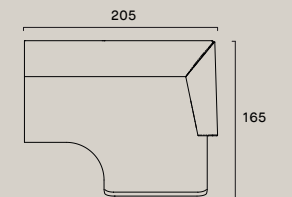

Gast (rounded right end section)  
Sofa  
FG 521.13

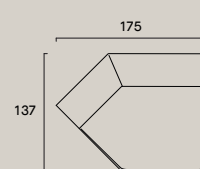

Gast (left lounge pentagon section)  
Sofa  
FG 521.14

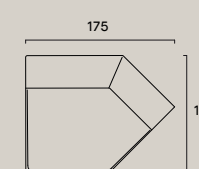

Gast (right lounge pentagon section)  
Sofa  
FG 521.15

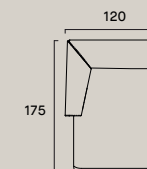

Gast (Chaise-longue)  
Sofa  
FG 521.20

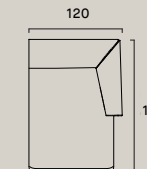

Gast (chaise-longue)  
Sofa  
FG 521.21

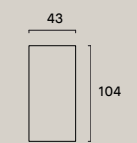

Gast (central element)  
Sofa  
FG 521.30

Tutti i divani Wilton hanno altezza 78 cm / All Wilton sofas are 78 cm high

## Hudson

↳ Day bed con struttura in massello di frassino. Gambe in metallo verniciato spazzolato. Cuscino di seduta imbottito in poliuretano espanso ignifugo rivestito in pelle con impunture matelassé. Cuscino poggiatesta in poliuretano sagomato rivestito in pelle.

↳ Day bed with solid ash wood frame. Brushed painted metal legs. Cushion padded with flame-retardant polyurethane foam and upholstered in leather with matelassé finish. Headrest in moulded polyurethane, upholstered in leather.

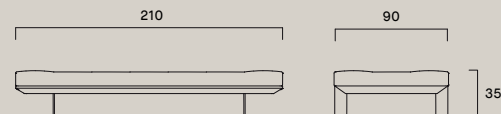

Hudson  
Day bed  
FG 477.00

## Winnie

↳ Collezione di divani con struttura in metallo leggermente imbottita e rivestita in pelle o tessuto. Cuscini di seduta e schienale imbottiti in piuma ecologica e rivestiti in pelle o tessuto. Piedini in ottone brunito o verniciati neri.

↳ Collection of sofas with lightly padded metal frame covered in leather or fabric. Seat and back cushions filled with eco-friendly down and upholstered in leather or fabric. Feet in brushed or painted black brass.

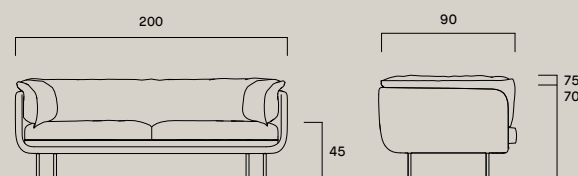

Winnie Sofa 200  
Sofa  
FG 483.01

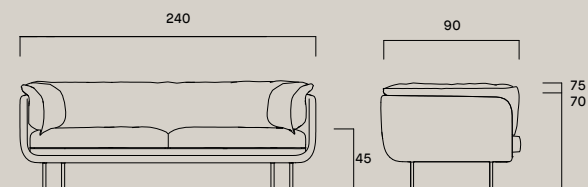

Winnie Sofa 240  
Sofa  
FG 483.02

## Wilton

↳ Collezione di divani chiusi ed elementi componibili. Struttura leggermente imbottita. Cuscini di seduta, braccioli e schienale rivestiti con trapuntino in piuma d'oca con inserto in poliuretano espanso. Rivestimento in cuoio (solo struttura) pelle o tessuto. Piedini in acciaio verniciato.

↳ Collection of fixed sofas and modular elements. Lightly padded body. Goose-down quilted lining of seat cushions, armrests and backrest with a polyurethane core. Upholstered in saddle leather (only body), leather or fabric. Steel feet in brushed brass or brushed dark grey finish.

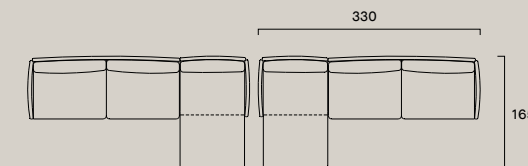

Composition 1  
M FG 511.04+FG 511.22  
M FG 511.06+FG 511.20

B FG 511.05+FG 511.23  
B FG 511.07+FG 511.21

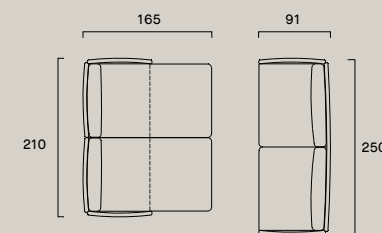

Composition 2  
M FG 511.02  
M FG 511.20+FG 511.22

B FG 511.03  
B FG 511.21+FG 511.23

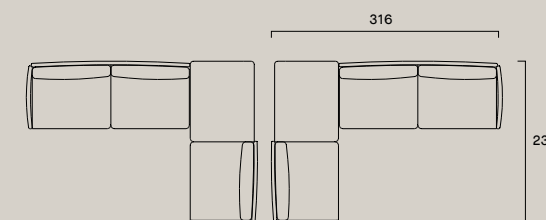

Composition 3  
M FG 511.04+FG 511.10  
M FG 511.06+FG 511.08

B FG 511.05+FG 511.11  
B FG 511.07+FG 511.09

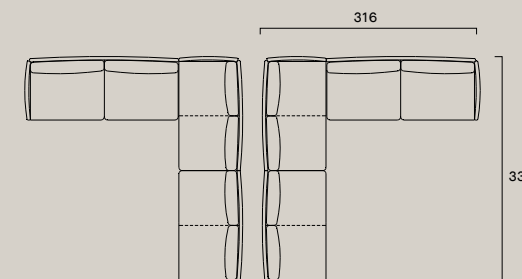

Composition 4 \*  
M FG 511.04+FG 511.12+FG 511.14  
M FG 511.06+FG 511.14+FG 511.12

B FG 511.05+FG 511.13+FG 511.15  
B FG 511.07+FG 511.15+FG 511.13

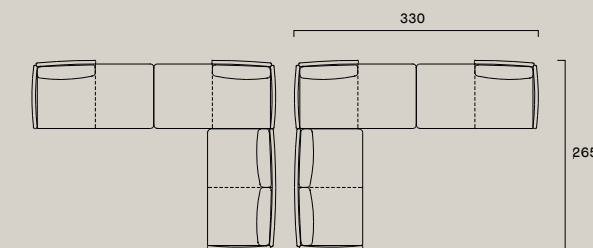

Composition 5 \*  
M FG 511.16+FG 511.18+FG 511.14  
M FG 511.16+FG 511.18+FG 511.12

B FG 511.17+FG 511.19+FG 511.15  
B FG 511.17+FG 511.19+FG 511.13

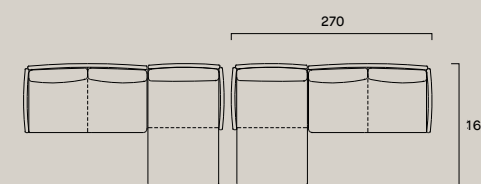

Composition 6  
M FG 511.12+FG 511.22  
M FG 511.14+FG 511.20

B FG 511.13+FG 511.23  
B FG 511.15+FG 511.21

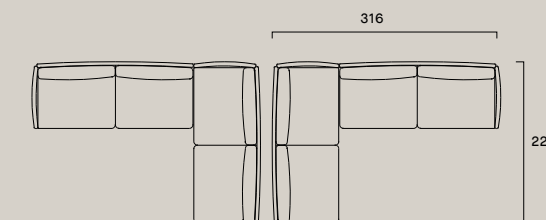

Composition 8 \*  
M FG 511.04+FG 511.04  
M FG 511.06+FG 511.06

B FG 511.05+FG 511.05  
B FG 511.07+FG 511.07

M = Monomaterial / B = Bimaterial \* Cushion mod. "E" recommended Sec. = Section

Tutti i divani Wilton hanno altezza 78 cm / All Wilton sofas are 78 cm high

Wilton

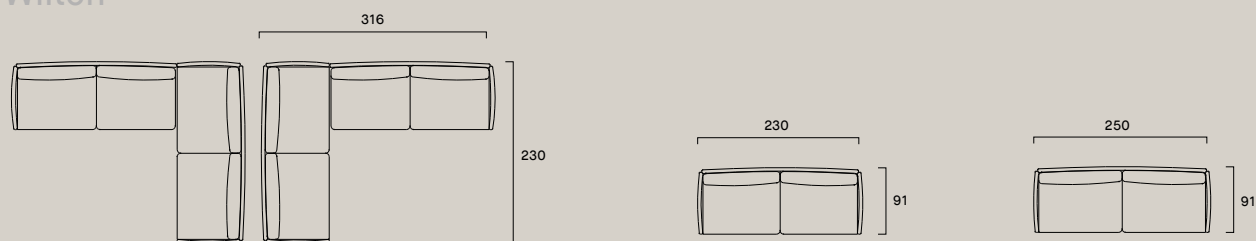

Composition 9  
 M FG 511.04+FG 511.00  
 M FG 511.06+FG 511.00  
 B FG 511.05+FG 511.01  
 B FG 511.07+FG 511.01

H40-62-78  
 FG 511.00 - Section M  
 FG 511.01 - Section B

H40-62-78  
 FG 511.02 - Section M  
 FG 511.03 - Section B



H40-62-78  
 FG 511.04 Left end corner Sec. M  
 FG 511.05-Left end corner Sec. B

H40-62-78  
 FG 511.06-Right end corner Sec. M  
 FG 511.07-Right end corner Sec. B

H40-62-78  
 FG 511.08-Left ottoman Sec. M  
 FG 511.09-Left ottoman Sec. B

H40-62-78  
 FG 511.10-Right ottoman Sec. M  
 FG 511.11-Right ottoman Sec. B



H40-62-78  
 FG 511.12-Left end corner Sec. M  
 FG 511.13-Left end corner Sec. B

H40-62-78  
 FG 511.14-Right end corner Sec. M  
 FG 511.15-Right end corner Sec. B

H40-62-78  
 FG 511.16-Left ottoman Sec. M  
 FG 511.17-Left ottoman Sec. B

H40-62-78  
 FG 511.18-Right ottoman Sec. M  
 FG 511.19-Right ottoman Sec. B



H40-62-78  
 FG 511.20-Left chaise longue-Sec. M  
 FG 511.21-Left chaise longue-Sec. B

H40-62-78  
 FG 511.22-Right chaise longue-Sec. M  
 FG 511.23-Right chaise longue-Sec. B

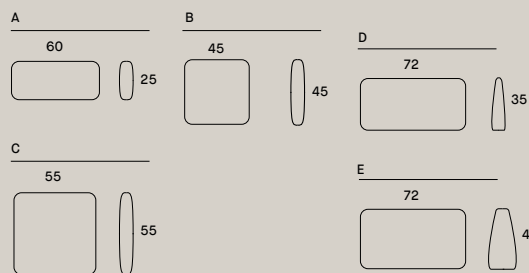

Cushions:  
 (A) AC 990.00 Cushion, (B) AC 990.01 Cushion, (C) AC 990.02 Cushion  
 Structural Cushions:  
 (D) AC 511.99 Armrest Cushion  
 (E) AC 511.98 Backrest Cushion

M = Monomaterial / B = Bimaterial \* Cushion mod. "E" recommended Sec. = Section

Arita

↳ Scrivania e consolle con struttura in acciaio verniciato nero e terminali in ottone con effetto spazzolato. Top disponibile in legno noce impiallacciato con bordo laccato bordeaux o vetro nero Mercurio.

↳ Desk and console with black painted steel structure and brass end-caps with brushed effect. Top available in walnut veneer with burgundy lacquered edge or Mercury black glass.

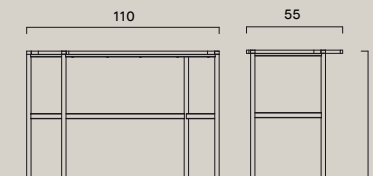

Arita Desk  
 Desk  
 FG 520.01

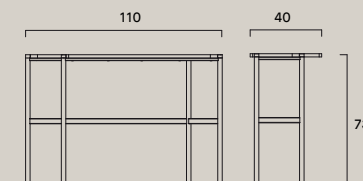

Arita Consolle  
 Consolle  
 FG 520.02

Dante

↳ Scrivania o tavolo interamente rivestito in cuoio. Piano con impunture.

↳ Desk or table fully upholstered in saddle leather. Top with stitching.



Dante 150  
 Desk  
 FG 366.00



Dante 180  
 Desk/Table  
 FG 366.02

Twain

↳ Scrivania con struttura in acciaio verniciato spazzolato e doppio piano rivestito in pelle.

↳ Desk with painted brushed steel frame and double tier top upholstered in leather.

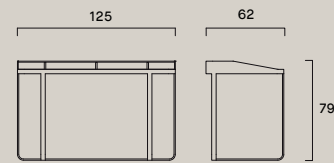

Twain  
Desk  
FG 444.00

Artù

↳ Tavolo tondo con base rivestita in pelle e dettagli in metallo con finitura in ottone spazzolato. Top in marmo. Su richiesta, vassoio girevole in marmo.

↳ Round table with a base covered in leather and metal details with a brushed brass finish. Marble top. Marble lazy Susan available upon request.

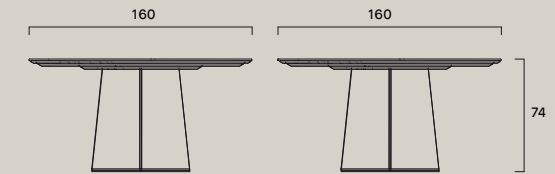

Artù 160  
Table  
FG 494.00

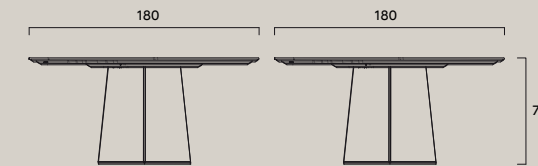

Artù 180  
Table  
FG 494.01

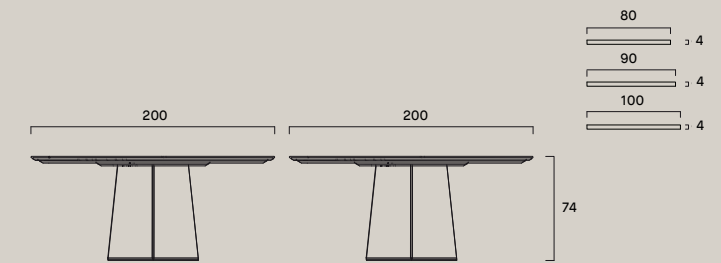

Artù 200  
Table  
FG 494.02

Lazy Susan  
AC FG 494.01, AC FG 494.02,  
AC FG 494.03

Blom

↳ Tavolo rettangolare con struttura in acciaio e gambe rivestite in cuoio. Top in marmo o vetro retroverniciato. Disponibile in tre misure.

↳ Rectangular table with steel frame and legs upholstered in saddle leather. Top in marble or varnished glass. Available in three sizes.

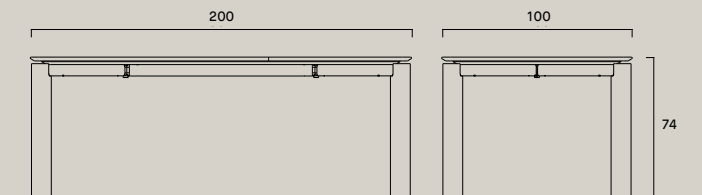

Blom 200  
Table  
FG 532.01

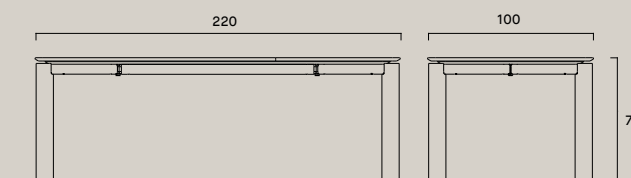

Blom 220  
Table  
FG 532.02

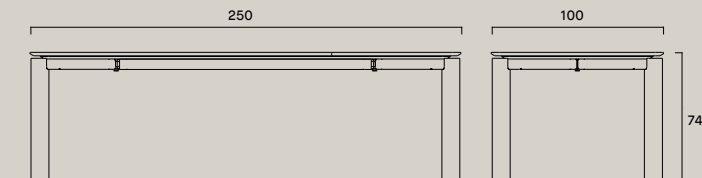

Blom 250  
Table  
FG 532.00



Bridge

↳ Tavolo con base in alluminio, piano in vetro temperato extrachiario o fumé o in marmi di collezione.

↳ Table with aluminium base, top in extra-clear or smoky tempered glass or marble from our collection.

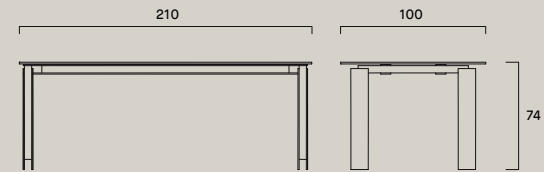

Bridge 210  
Table  
FG 453.01

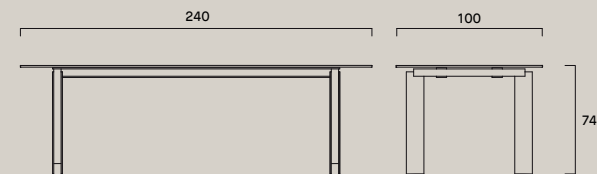

Bridge 240  
Table  
FG 453.00

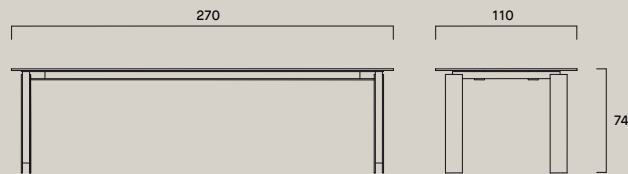

Bridge 270  
Table  
FG 453.02



Bridge 300  
Table  
FG 453.03

Dante

↳ Scrivania o tavolo interamente rivestito in cuoio. Piano con impunture.

↳ Desk or table fully upholstered in saddle leather. Top with stitching.

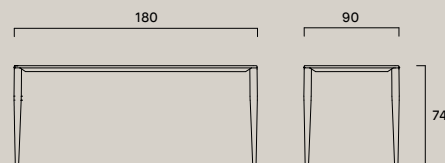

Dante 180  
Desk/Table  
FG 366.02

Doni

↳ Tavolo con base in acciaio verniciato, piano nei marmi di collezione. Disponibile in 3 altezze, lounge, dining e bar.

↳ Table with painted steel base, top in a choice of marble from our collection. Available in 3 heights, lounge, dining and bar.

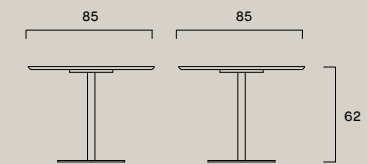

Doni 62  
Lounge table  
FG 485.01

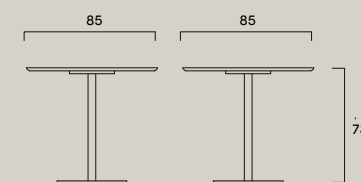

Doni 73  
Table  
FG 485.00

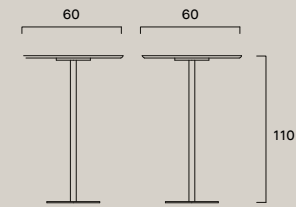

Doni 110  
Bar table  
FG 485.02

Myon

↳ Tavolo tondo e ovale in fibra di legno mdf laccato lucido.

↳ Round or oval table in glossy laquered mdf wood fiber.

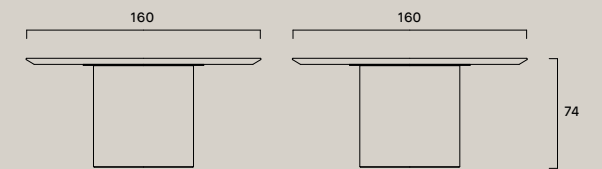

Myon 160  
Table  
FG 541.00

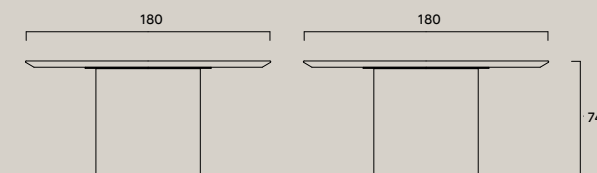

Myon 180  
Table  
FG 541.01

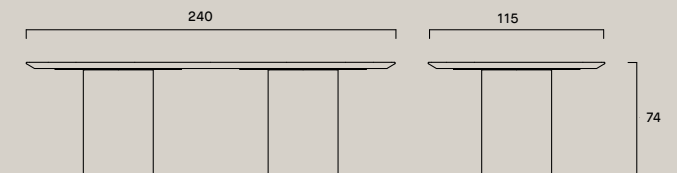

Myon 240  
Table  
FG 541.10

Myon

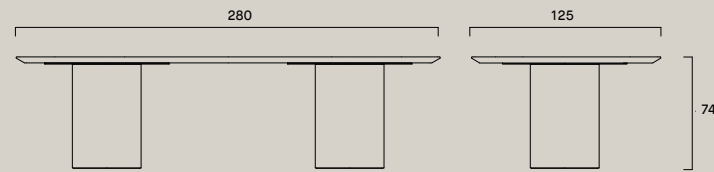

Myon 280  
Table  
FG 541.11

Paipu

↳ Tavolo tondo e ovale con base in tubi d'acciaio curvato e verniciati grigio scuro spazzolato. Top in marmo o vetro retroverniciato nero.

↳ Round and oval table with a base in curved steel tubes and finished in brushed dark grey. Marble or back-painted glass top.

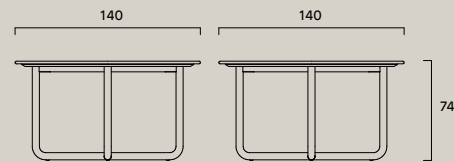

Paipu 140  
Table  
FG 522.01

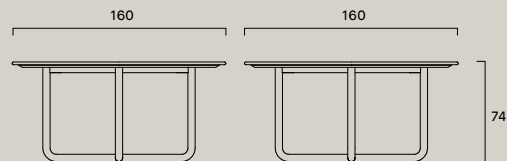

Paipu 160  
Table  
FG 522.00

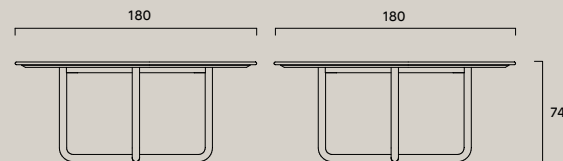

Paipu 180  
Table  
FG 522.02

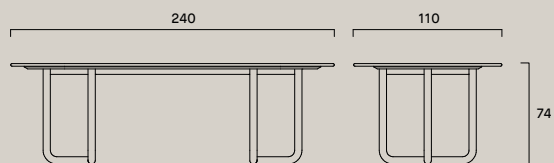

Paipu 240  
Table  
FG 522.11

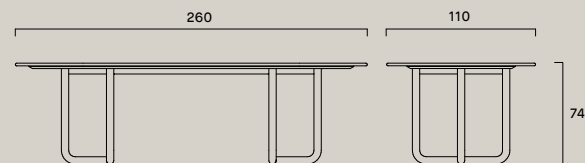

Paipu 260  
Table  
FG 522.10

Arita

↳ Tavolino fronte divano con struttura in acciaio verniciato colore nero e terminali in ottone con effetto spazzolato. Top disponibile in legno noce impiallacciato con bordo laccato bordeaux o vetro nero Mercurio.

↳ Coffee table with black painted steel structure and brass end-caps with brushed effect. Top available in walnut veneer with burgundy lacquered edge or Mercury black glass.



Arita CT  
Coffee table  
FG 520.00

Bler

↳ Tavolino fianco divano con struttura e top in acciaio verniciato effetto spazzolato e gamba rivestita in cuoio. Disponibile in due misure.

↳ Sofa side table with steel structure and top, finished with a brushed effect, leg upholstered in saddle leather. Available in two sizes.

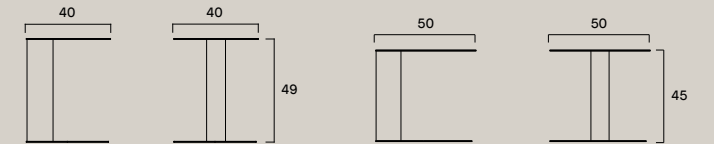

Bler 40  
Side table  
FG 538.00

Bler 50  
Side table  
FG 538.01

Clubby

↳ Tavolino imbottito rivestito in pelle o tessuto. Top in mdf finitura ottone spazzolato.

↳ Padded coffee table upholstered in leather or fabric. Mdf top finished in brushed brass.

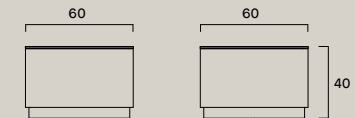

Clubby CT  
Coffee table  
FG 493.50

Comb

↳ Tavolini fronte e fianco divano con struttura in tondino di metallo, disponibile in finitura ottone spazzolato o verniciato nero. Piano in mdf laccato.

↳ Collection of accent tables with metal rod frame, available in brushed brass or black painted finish. Top in lacquered MDF.

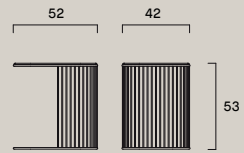

Comb 40  
Side table  
FG 487.02

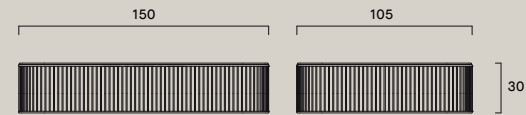

Comb 100  
Coffee table  
FG 487.01

Myon

↳ Set di tavolini fronte e fianco divano in fibra di legno mdf laccato lucido. Myon 48 e Myon 80 hanno una base zavorrata.

↳ Set of accent tables in glossy laquered mdf wood fiber. Myon 48 and Myon 80 have a ballasted base.

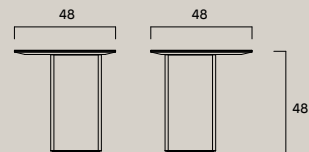

Myon 48  
Side table  
FG 541.50

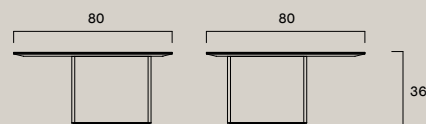

Myon 80  
Coffee table  
FG 541.51

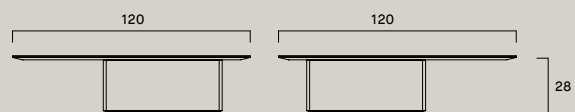

Myon 120  
Coffee table  
FG 541.52

Quattro

↳ Set di tavolini fronte e fianco divano con struttura in tubo d'acciaio curvato verniciato colore nero opaco, ripiano in marmo.

↳ Set of side and coffee tables with matt black painted curved steel tube frame and marble top.

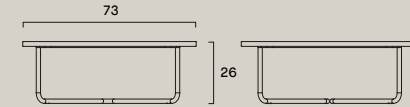

Quattro CT 26  
Coffee table  
FG 518.52

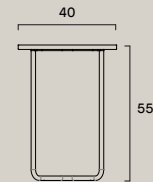

Quattro CT 55  
Side table  
FG 518.51

Square

↳ Set di tavolini fronte e fianco divano con struttura in tubo d'acciaio verniciato e puntali in alluminio o ottone spazzolato. Piano nei marmi di collezione.

↳ Set of accent tables made of lacquered tubular steel structure with brushed solid aluminium or brass tips. Top in a choice of marbles from our collection.



Square 24  
Coffee table  
FG 465.51

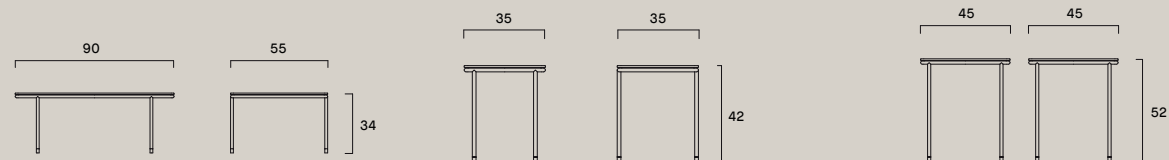

Square 34  
Coffee table  
FG 465.50

Square 42  
Side table  
FG 465.53

Square 52  
Side table  
FG 465.52



Square 100  
Coffee table  
FG 465.54

Square 140  
Coffee table  
FG 465.56

Bak Valet Stand

↳ Appendiabiti con struttura in acciaio verniciato spazzolato con inserti in pelle, ripiani tondi in acciaio leggermente imbottiti e parzialmente rivestiti in pelle. Disponibile con o senza specchio.

↳ Valet stand featuring a painted brushed steel frame with leather inserts, lightly padded round steel shelves partially upholstered in leather. Available with or without mirror.

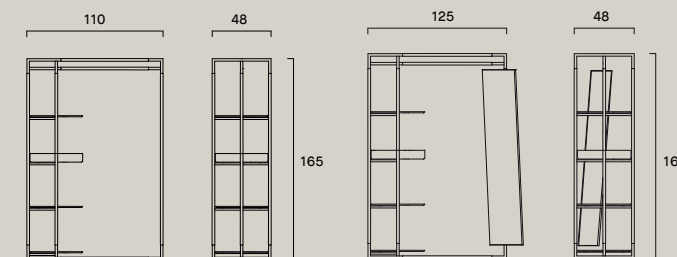

Bak valet stand  
Valet stand  
FG 440.00

Bak valet stand mirror  
Valet stand  
FG 440.01

Bak Bookcase

↳ Libreria con struttura in acciaio verniciato spazzolato con inserti in pelle, ripiani in MDF rivestiti con tranciato in legno di noce.

↳ Bookcase with painted brushed steel frame and leather inserts, walnut veneered MDF shelves.

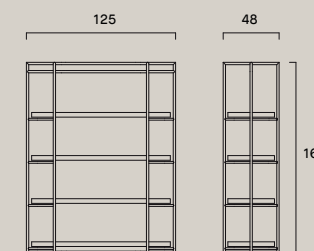

Bak bookcase  
Bookcase  
FG 440.10

Loren

↳ Letto composto da testiera e struttura con vano contenitore in multistrato imbottito e rivestito in pelle o tessuto sfoderabile. Disponibile in due misure.

↳ Bed composed of headboard and storage compartment in plywood, padded and upholstered in leather or with removable fabric cover. Available in two sizes.

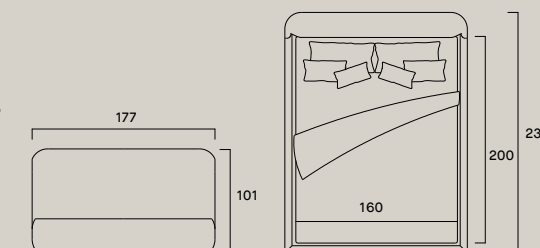

Loren 160  
Bed  
FG 531.04

Mattress 160x200 cm

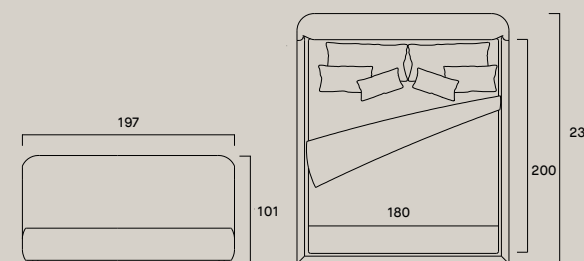

Loren 180  
Bed  
FG 531.05

Mattress 180x200 cm

Morgans

↳ Libreria a parete con struttura in alluminio anodizzato, mensole rivestite in cuoio.

↳ Anodised aluminium bookcase with saddle-leather upholstered shelves.

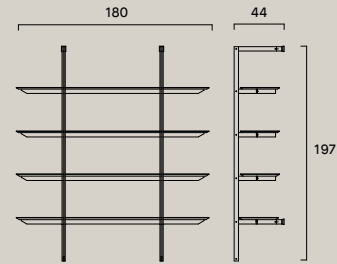

Morgans  
Bookcase  
FG 507.00

Otto

↳ Letto composto da struttura e testata in legno multistrato imbottito e rivestito in pelle. Piedini in metallo verniciato in colore nero e puntali con finitura ottone spazzolato.

↳ Bed composed of a frame and a headboard in plywood, padded and upholstered in leather. Feet in black varnished metal and tips finished in brushed brass.

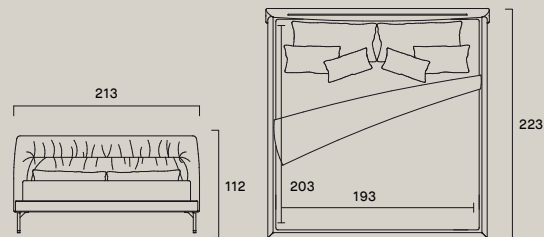

Otto King  
King bed  
FG 517.01

Mattress 193 × 203 cm

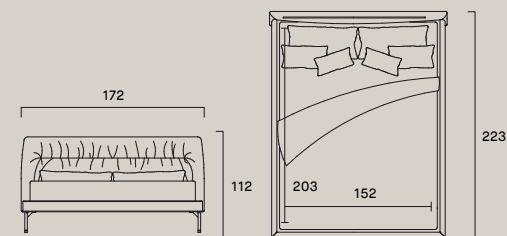

Otto Queen  
Queen bed  
FG 517.00

Mattress 152 × 203 cm

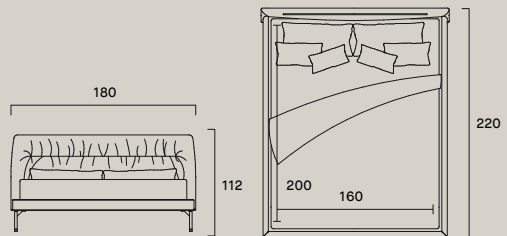

Otto 160  
Bed  
FG 517.04

Mattress 160 × 200 cm

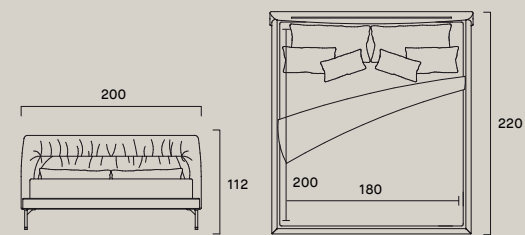

Otto 180  
Bed  
FG 517.05

Mattress 180 × 200 cm

Privé

↳ Famiglia di mobili contenitori, madia e credenza. Struttura composta da pannelli di particelle di legno rivestiti con tranciato in legno di noce. Mensole interne in vetro extrachiaro temperato. Basamento in tubolare d'acciaio verniciato con puntali in alluminio spazzolato. Madia disponibile con e senza cassetti. Top in pelle.

↳ Collection of storage units, cupboard and side board. Frame made of walnut veneered particleboard panels. Inside shelves in extra-clear tempered glass. Base in painted tubular steel with brushed aluminium tips. Side board available with or without drawers. Leather top.

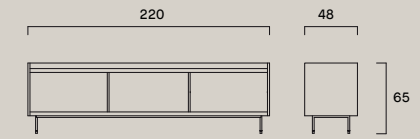

Privé A  
Side board  
FG 478.01

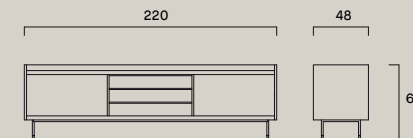

Privé B  
Side board with drawers  
FG 478.00

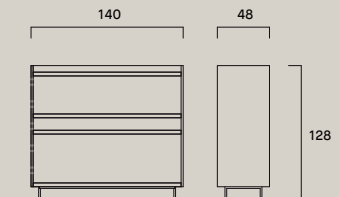

Privé C  
Cup board  
FG 478.10

Twin

↳ Collezione di specchi, ovale da terra e tondo a muro, con cornice in acciaio verniciato ottone spazzolato.

↳ Collection of mirrors including an oval floor version and a wall mounted round version with a brushed brass painted steel frame.

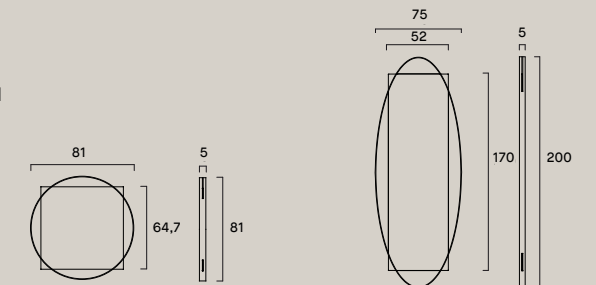

Twin One  
Mirror  
FG 524.00

Twin Duo  
Mirror  
FG 524.01

Viae

↳ Servomuto con struttura in tondino metallico, finitura ottone spazzolato o verniciato nero. Servomuto con ripiani e appendiabiti rivestiti in cuoio.

↳ Valet stand with a metal rod frame with brushed brass or black painted finish, shelf and clothes stand upholstered in saddle leather.

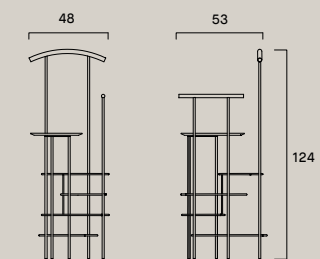

Viae Valet Stand  
Valet stand  
FG 484.50

# Colophon

## Company info

Frag Srl  
Via dei Boschi 2  
33040 Pradamano  
Udine Italia  
Tel. +39 0432 671375  
frag@frag.it  
www.frag.it

## Credits

Art Direction  
R+W

Concept and design  
Choice—Studio

Layout  
Choice—Studio

Project coordination  
Federica di Fonzo

Photos  
Photographer  
Gionata Xerra  
Miro Zagnoli

Photo assistant  
Leonardo Duggento

Stylist  
Simona Silenzi Studio  
Stylist Assistant  
Gaia Marchesini

Photo retouching  
Malvina Monteggia

Color separation  
Lucegroup

Print  
OGM SpA

April 2023

## Thanks to

CC Tapis  
Vano Alto  
Oluce  
ZPSTUDIO  
Artemide  
Bitossi Home  
Ghidini 1961  
Gumdesign  
Hands on Design  
Ichendorf Milano  
Maddalena Selvini  
Carpet Edition  
Kalakera

The colour reproduced in the images, printed or in video, may differ from the actual colour of the material and should be regarded as a mere example. For a real comparison, we recommend using an original colour sample of the material.

Frag reserves the right to introduce any changes to its own models without prior notice. Color tones may vary from one dye lot to another.

© 2023 by Frag srl  
All rights reserved

